

CEDAR *Special*

Computerized Controller for High Speed Doubling & Tacking Machine Operation Manual Model CS-0606HS-22



Collier Equipment

The home of **CEDAR** *Special* &
CEDAR Systems Automated Sewing Devices

100 Mill Creek Circle/Po Box 175
Lexington, Alabama 35648 USA
Phone: (256)229-6595 Fax: (256)229-6779

Table of Content

| | |
|---|----|
| 1 General Information | 1 |
| 1.1 General | 1 |
| 1.2 Technical Parameters..... | 1 |
| 1.3 Matters for Safe Using | 2 |
| 1.4 The Preventions on Usage..... | 4 |
| 1.5 Standardization..... | 5 |
| 1.6 Operation Method | 6 |
| 2 Operating Instruction | 6 |
| 2.1 Common Buttons | 6 |
| 2.2 Basic Operation..... | 7 |
| 2.3 Operation of Normal Pattern..... | 8 |
| 2.4 Pattern Registration..... | 11 |
| 2.5 Pattern Naming | 12 |
| 2.6 Winding..... | 12 |
| 2.7 Pattern Selection | 14 |
| 2.8 Sewing Data Setting..... | 16 |
| 2.9 P Pattern Registration..... | 17 |
| 2.10 Trial Sewing..... | 18 |
| 2.11 Counter Operation..... | 20 |
| 2.12 Emergency Stop | 21 |
| 3 Operations on Prompt (P) Pattern..... | 23 |
| 3.1 P Pattern Data Input | 23 |
| 3.2 P Pattern Edition..... | 25 |
| 3.3 P Pattern Copy..... | 26 |
| 3.4 P Pattern Selection | 27 |
| 3.5 P Pattern Sewing: | 28 |
| 4 Operations on Combination (C) Pattern | 30 |
| 4.1 C Pattern Data Input..... | 30 |
| 4.2 C Pattern Edition..... | 31 |
| 4.3 C Pattern Selection..... | 33 |
| 4.4 C Pattern Sewing..... | 34 |
| 5 Pattern Edition..... | 36 |
| 5.1 Have Access to Pattern Edition Mode..... | 36 |
| 5.2 Pattern Edition..... | 39 |
| 5.3 Quit Pattern Edition Mode | 45 |
| 6 Information Functions..... | 46 |
| 6.1 Maintenance & Repair Information | 46 |
| 6.2 Input Time for Maintenance & Repair | 47 |
| 6.3 How to Release Alarm | 49 |
| 6.4 Production Control..... | 49 |
| 6.4.1 Via Information Interface..... | 50 |
| 6.4.2 Via Sewing Interface..... | 51 |

| | |
|--|-----|
| 6.4.3 Setting on Production Control..... | 51 |
| 6.5 Display Threading Figure..... | 54 |
| 6.6 Alarm Record | 55 |
| 6.7 Running Record | 57 |
| 6.8 Setting of Periodical Password..... | 58 |
| 7 Communication Functions | 64 |
| 7.1 About the Available Data..... | 64 |
| 7.2 Operations | 65 |
| 7.3 Pattern Transfer | 65 |
| 7.4 Parameter Transfer | 69 |
| 7.5 Software Update..... | 71 |
| 8 Mode & Parameter Setting..... | 73 |
| 8.1 List of Function Keys..... | 74 |
| 8.2 Level 1 Parameters Setting..... | 75 |
| 8.3 Level 2 Parameters Setting..... | 81 |
| 8.4 Counter Setting | 85 |
| 8.4.1 Functions | 86 |
| 8.5 Change Sewing Mode | 87 |
| 8.6 Have Access to Pattern Edition | 87 |
| 8.7 Set Pattern Lock | 88 |
| 8.8 Initialization | 88 |
| 8.9 Software Version Inquiry | 91 |
| 8.10 Test Mode..... | 91 |
| 8.11 Keyboard Lock..... | 97 |
| 8.12 Parameter Back-up..... | 99 |
| 8.13 Button-stitching Function Setting | 100 |
| 8.14 Pattern Edition Parameter Setting | 103 |
| 9 Controller System Principle | 104 |
| 9.1 Structure of Control System..... | 104 |
| 9.1.1 Diagram of Control System..... | 104 |
| 9.1.2 External Cable Connection of Control Box | 105 |
| 9.2 List of Patterns in 1900B Controller | 106 |
| 9.3 List of Patterns for Button-sewing in 1900B Controller | 109 |
| 9.4 List of Patterns for Doubling in 1900B Controller..... | 110 |
| 9.5 List of Warning..... | 114 |
| 9.6 Hint List | 117 |

1 General Information

1.1 General

This computerized control system for sewing machine features the following advantages: 1) Adoption of the world leading AC servo control technology on main shaft motor provides high torque, good efficiency, stable speed and low noise; 2) Diversified design of control panel can meet the special requirement of users on attachment; 3) System adopts German style structure, which offers easy installation and maintenance to users; 4) The system control software can be updated via the remote communication, which is easy for user to improve the performance of machine.

1.2 Technical Parameters

| No. | Items | Model Touching Panel CS-1965 |
|-----|--------------------------|--|
| 1 | Usage | Doubling & Tacking, Button Sewing |
| 2 | Sewing Range | X(Left/ Right) Direction 60mm × Y(Forward/Backward) Direction 50mm |
| 3 | Max Speed | Max 3000rpm (For Double Hook type, it is 2700rpm) |
| 4 | Min Sewing Unit | 0.1mm |
| 5 | Cloth-feeding | Indirect Cloth-feeding (Pulse Motor Dual-shaft Drive) |
| 6 | Stroke of Needle Bar | 41.2mm |
| 7 | Needle | DP ×5 #14 (DP×5 #11(F,M), (DP×17#21 Thick Fabric)) |
| 8 | Presser-lifting Device | Mechanical |
| 9 | Presser Height | Standard 14mm, Max 17mm(at Reverse Lifting) |
| 10 | Standard Pattern Number | 50/100 |
| 11 | Method for Thread-wiping | Interaction by lifting presser with solenoid |
| 12 | Upper Thread Tension | Electronic |
| 13 | Hook | Semi-rotation standard hook |
| 14 | Oiling Method | Rotation Part: Slight Oiling |
| 15 | Oil | Sewing machine oil |
| 16 | Lubricating Grease | Lubricating grease for sewing machine |
| 17 | Data Memory | U Disk |
| 18 | Scaling Function | Independent scaling 20% ~200% at X direction and Y direction respectively (1% for each step) |
| 19 | Scaling Method | Change Stitch form length and stitch interval |
| 20 | Sewing Speed | 400-3000rpm(100rpm per step) |
| 21 | Patten Selection | By selecting the number of pattern (1-200) |

| | | |
|----|-----------------------|---|
| 22 | Bottom Thread Counter | Up/Down Method (0~9999) |
| 23 | Motor | 500W Small AC Servo Motor (Direct Drive Mode) |
| 24 | Size | 263mm×153mm×212mm |
| 25 | Weight of Control Box | About 10 Kg |
| 26 | Power | 600W |
| 27 | Working Temperature | 5°C - 40°C |
| 28 | Working Humidity | 35% - 85% (No Dew) |
| 29 | Voltage Input | Single Phase AC 220V ± 10%; 50-60Hz |

※ At daily usage, please lower the max sewing speed according to the sewing condition.

1.3 Matters for Safe Using

● Working Environment

Do not use this control device in the following environments:

- Power Voltage
 - ◆ Voltage fluctuation beyond ±10% of the standard voltage.
 - ◆ Capacity of power supply doesn't meet the requirement
- Electrical Disturbance
 - ◆ The area beside the wave launcher with strong electrical wave and magnetic field or the high cyclic machine
- Temperature/ Humidity
 - ◆ Temperature below 0°C or above 50°C
 - ◆ Outdoors or the area directly shined by sun
 - ◆ Beside stove (heater).
 - ◆ Relating humidity below 5% or above 95% or the area without dew
- Air
 - ◆ Dusty area or area with corrosive gas
 - ◆ Area that is easy to have air explosion or oil explosion
- Vibration
 - ◆ If the location of the sewing machine usually has excessive vibration, please move the control box to other place

● Installation

- Control Box
 - ◆ Please install the control box according to the instruction
- Attachments
 - ◆ If other attachments are needed, please turn off the power and pull off the power plug.
- Power Cable
 - ◆ Do not press power cable with force or excessively twist power cable.
 - ◆ The power cables shall be fixed with a distance at 25mm away from the rotating component at least.

- ◆ Before powering the control box, user shall carefully check the voltage of power supply and position of power input on control box. If the power transformer is used, user should also check it before powering the machine. At this moment, the power switch of sewing machine must be set as “Off”.
- Grounding
 - ◆ In order to avoid the noise disturbance and shock caused by electrical leakage, user should ground the grounding cable.
- Attachments
 - ◆ If the electrical attachments are needed, please connect them to the proper positions.
- Disassemble
 - ◆ When removing the control box, user should turn off the power and pull off the power plug.
 - ◆ At pulling off the power plug, user should hold the plug and remove it, instead of pulling the power cable only.
 - ◆ The control box contains the dangerous high voltage power. For opening the control box, please turn off the power and take away the plug from socket firstly, and then wait for at least 5 minutes before opening the control box.

● **Maintenance, Inspection and Repair**

- Only can the trained technicians perform the repair and maintenance of this machine.
- When replacing the needles and shuttles, user has to turn off the power.
- Please use the spare parts from the authorized manufacturers

● **Others**

- Do not touch the rotating or moving part of the machine, especially the needle and belt, when the machine is working. User should also keep his/her hair away from those moving parts, so as to avoid the danger.
- Do not drop the control device on the floor, nor insert ant stuff into the slot on the control box.
- Do not run the machine without the cover shells
- If this control device is damaged or unable to work normally, please ask the technicians to adjust or repair it. Do not run the machine when the problem is not solved
- Please do not change or modify the control device without authorization

● **Abandonment**



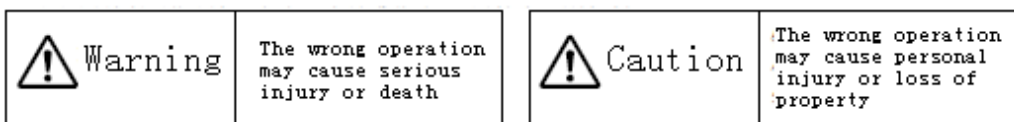

- Dispose it as common industrial trash.

● **Warning and Danger**

- The mistake operation may cause danger. For the serious level, please refer to the figure at below:



- The meaning of the figure are shown at below:

| | | | |
|---|---|---|-----------------------|
|  | Please operate machine according to instruction |  | Caution: High Voltage |
|  | Caution: High Temperature |  | Grounding is a must |
|  | Never do this. | | |

1.4 The Preventions on Usage

Warning.

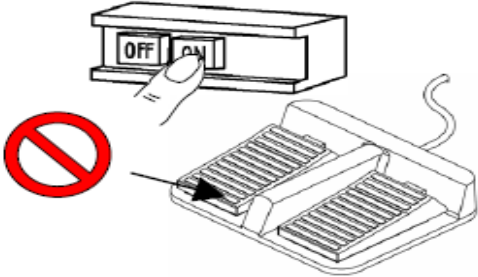
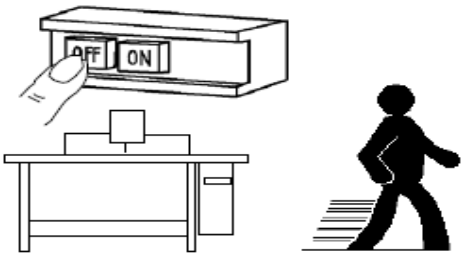
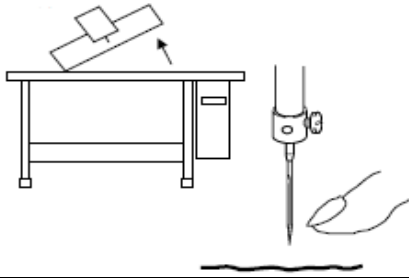
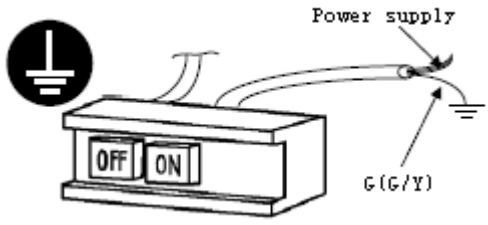
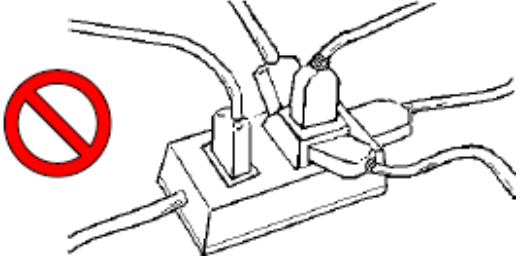
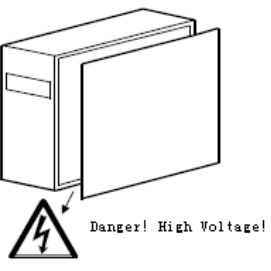
| | |
|---|--|
| <p>1、When you press [ON], leave the feet from pedal.</p>  | <p>2、When you leave the machine, please turn it off.</p>  |
| <p>3、If user needs tilt the head or replace the needle or thread the Needle thread, please turn off the power</p>  | <p>4、Grounding the machine with ground cable</p>  |
| <p>5、Do not use the household terminal block to let machines to share one power supply</p>  | <p>6、For opening the control box, please turn off the power and take away the plug from socket firstly, and then wait for at least 5 minutes before opening the control box</p>  |
| <p>7、After replacing the motor, please set the installation angle of main motor according to this</p> | |

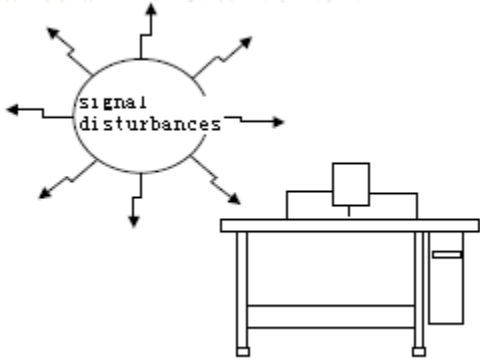
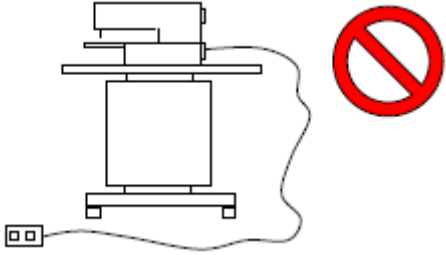
| | |
|---|--|
| documents. | |
| <p>8、 Please keep it away from the machine creating the high cyclic disturbance</p>  | <p>9、 If user needs the external signal socket to connect the attachments, the connecting wire shall be as short as possible. The long cable may cause the wrong operation. And the connection cable shall be the isolated cable.</p>  |
| <p>10、 If the fuse is burnt, please solve the problem before replacing a new one with same capacity</p> | |

1.5 Standardization

The button using the common figure can be understood by the users from different countries.

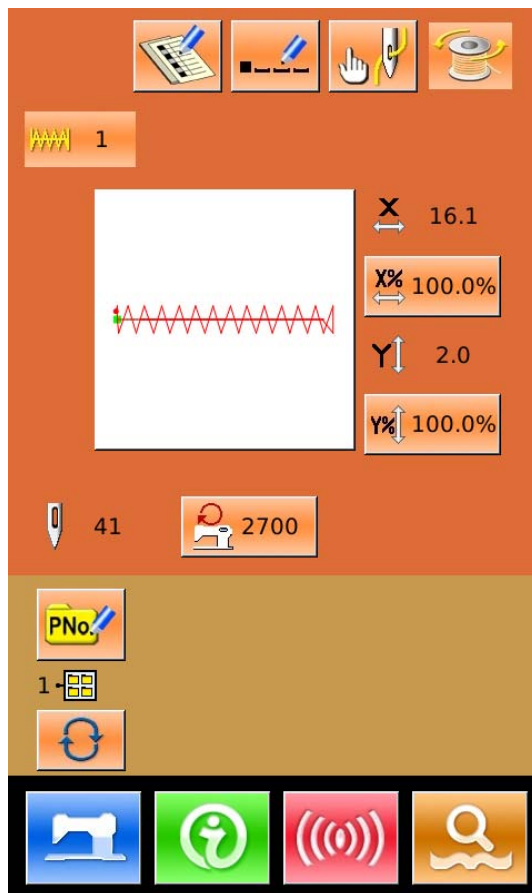

1.6 Operation Method

We use the advanced touching operation technique on the operation panel, whose friendly interface and simple operation will bring the big changes to users in their usage. Users can finish the relating operations by using their fingers or other object to touch the screen. **Never use sharp object to touch the screen, otherwise the touching panel will suffer the permanent damage.**

The function keys include Ready Key, Information Key, Mode Key and Communication Key. For the specific operation, please refer to the chapters at below:



Never use sharp object to touch the screen, otherwise the touching panel will suffer the permanent damage.

2 Operating Instruction

2.1 Common Buttons

The buttons for the common operation in each interface are shown at below:

| No. | Figure | Functions |
|-----|--------|---|
| 1 | | ESC → Quit the current interface. At data change interface, it is for canceling the change of data. |
| 2 | | Enter → Confirm the changed data. |
| 3 | | Plus → Increase the value |
| 4 | | Minus → Decrease the value |
| 5 | | Reset → Release the Error |
| 6 | | Number Input → Display the number keyboard and input the number. |
| 7 | | READY Key → Shift between the data input interface and sewing interface |
| 8 | | Information Key → Shift between the data input interface and information interface |
| 9 | | Communication Key → Shift between the data input interface and communication interface |
| 10 | | Mode Key → Shift between the data input interface and communication interface |

2.2 Basic Operation

① Turn on the power

Turn on the power to display the data input interface.

② Select the wanted pattern No.

At current interface, the selected pattern No. will be

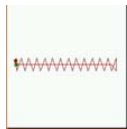

displayed. Press  to select pattern

number.

For the operation of pattern selection, please refer to

【2.7 Pattern Selection】 .

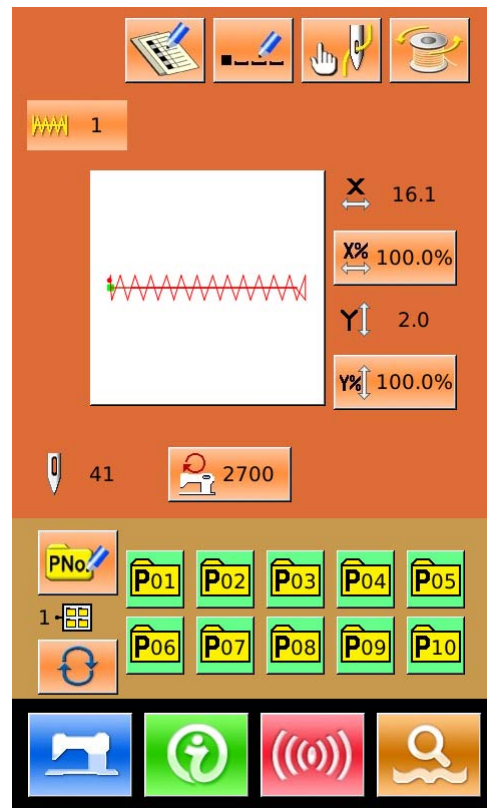

③ Set machine to Ready Sewing Status

Press READY key . The back-light of LCD displayer changes to blue color and the machine is ready for sewing.

④ Start Sewing

Set the sewing product to the presser position; operate the pedal to start the sewing machine, and sewing starts

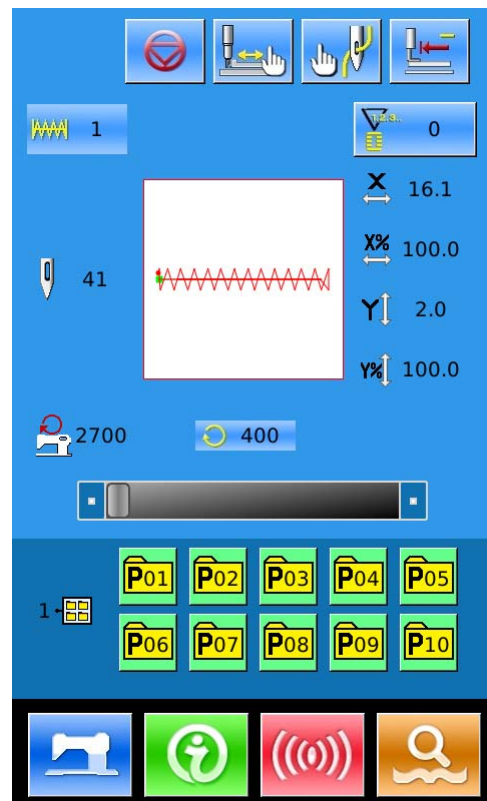

2.3 Operation of Normal Pattern

(1) Sewing Data Input Interface

The data input interface is shown at right. For the detailed functions, please refer to the Function Key List

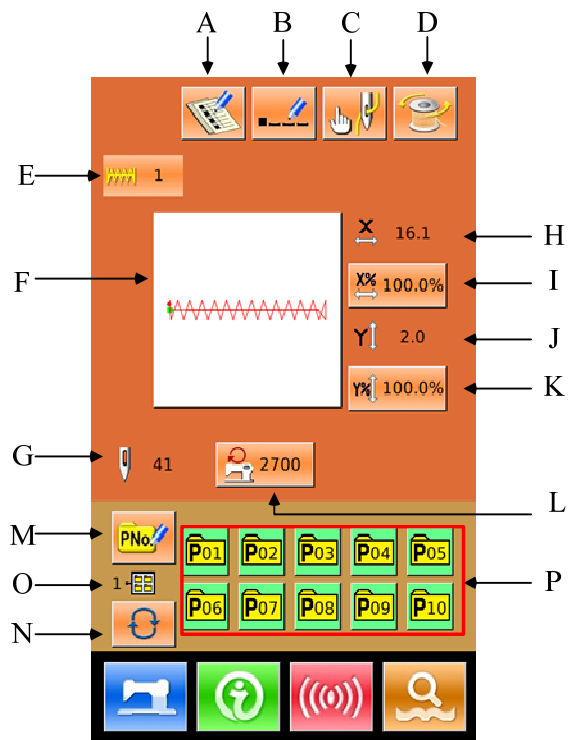

Function Key List:

| No. | Function | Content |
|-----|--------------------------|--|
| A | Pattern Registration | At most, 999 normal patterns can be registered. |
| B | Pattern Naming | At most, 14 figures can be input. |
| C | Threading | Lower the presser to display the interface. For lifting the presser, please press “Presser Up” button. |
| D | Winding | Press  to start winding. |
| E | Pattern No. Display | Display the current pattern number |
| F | Sewing Pattern Selection | The button will display the shape of the current pattern. Press it to enter the interface for selecting patterns |
| G | Pattern Stitch Number | Display stitch number of the current pattern |
| H | X Actual Size | Display the actual size of current pattern at X direction. Use parameter U64 to input the actual size, at this moment the X Actual Size button is displayed. |
| I | X Scale Rate | The button will display the X scale rate of the current pattern. Press it to enter the interface for setting. It is affected by parameters U64 & U88. |
| J | Y Actual Size | Display the actual size of current pattern at Y direction. Use parameter U64 to input the actual size, at this moment the Y Actual Size button is displayed. |

| | | |
|---|---|---|
| K | Y Scale Rate | The button will display the Y scale rate of the current pattern. Press it to enter the interface for setting. It is affected by parameters U64 & U88. |
| L | Max Speed | Display the Max Speed. Press this button to set the speed |
| M | Prompt Pattern (P Pattern) Registration | It is used for P pattern registration. At most, 50 P patterns can be registered. |
| O | P Pattern File Folder Number | Display the file folder number of current P pattern |
| N | P Pattern File Folder Selection | Shift P pattern file folder number orderly. |
| P | P Pattern Selection | Display the registered P pattern. Press it to enter the interface for inputting P pattern data. This button is not displayed at initial status. |

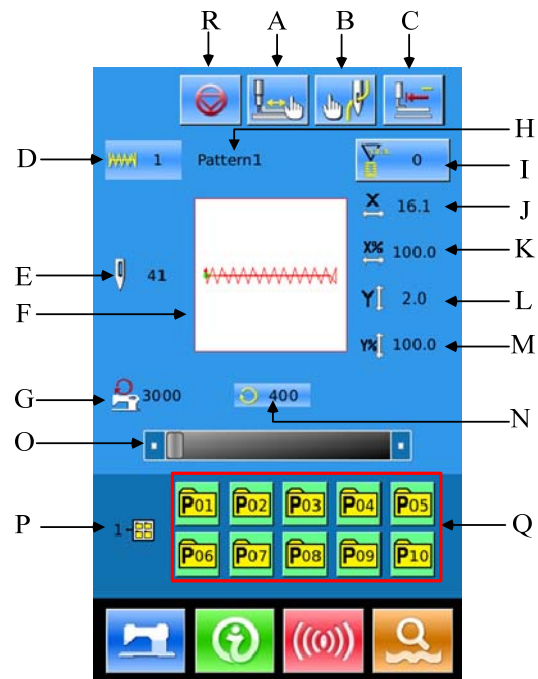

(2) Sewing Interface

Press  to enter the Sewing Interface shown as the figure at right. For detailed functions please take the Function Key List for reference.



Function Key List:



| No. | Function | Content |
|-----|------------------|---|
| A | Trial Sewing | Press it to enter the trial sewing interface, where the pattern shape can be set. |
| B | Presser Down | Lower presser to display the presser down interface. For lifting the presser, please press the “Presser Up” Button. |
| C | Return to Origin | Press it to have presser return to the start sewing point and go up. |
| D | Pattern Number | Display the number of the current pattern |

| | | |
|---|------------------------------|--|
| E | Pattern Stitch Number | Display the stitch number of the current pattern |
| F | Pattern Shape | Display the shape of the current pattern |
| G | Max Speed | Display the Max Speed |
| H | Pattern Name | Display the name of the current pattern. |
| I | Counter Setting | Press it to set the counter type and current counter value  : Sewing Counter  : No. of piece counter |
| J | X Actual Size | Display the X actual size of current pattern |
| K | X Scale Rate | Display the X scale rate of current pattern |
| L | Y Actual Size | Display the Y actual size of current pattern |
| M | Y Scale Rate | Display the Y scale rate of current pattern |
| N | Sewing Speed | Display the current sewing speed |
| O | Set Sewing Speed | Change the sewing speed |
| P | P Pattern File Folder Number | Display the number of the current P pattern file folder |
| Q | P Pattern Selection | Display the registered P pattern. Press it to enter the interface for sewing P pattern. This button is not displayed at initial status. |
| R | Pause | Press it to stop the machine. It is affected by parameter U31. When this button is selected, the interface will only display this button |

2.4 Pattern Registration

999 normal patterns can be registered for the most. press  to enter the interface of Pattern Registration (shown as the right figure):

① Input Pattern No.

Input the pattern No. via keyboard. If the pattern number is already existed in the system, the look and relevant information of the registered pattern will be shown on the upper interface. The used number can't be reused, but by pressing ,  the unregistered number can be searched.

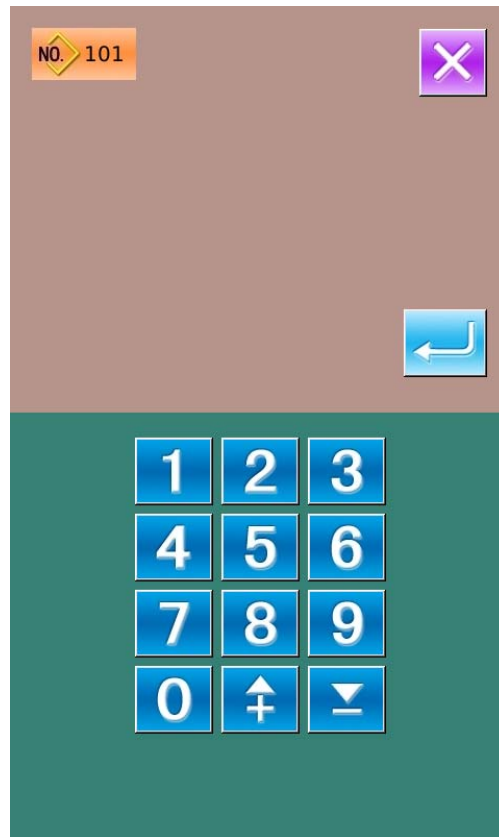

② New Pattern Registration

After confirm the pattern number, user can press . The displayed pattern data will be copied to the newly registered pattern. After the operations, the system will return to the interface for inputting data of the newly registered pattern

If user inputs the existed pattern number, the system will ask user whether to replace the saved pattern.

Note: the Basic pattern cannot be replaced

2.5 Pattern Naming

Press  to enter the interface for naming pattern (as shown in the right figure), 14 figures can be inputted at the most.

 : Icon Right-moving

 : Icon Left-moving

 : Caps Locks

 : Eraser

Select the figure wanted, press  to end the operation of naming the pattern.

The position of figure can be determined by moving the icon, the Eraser is used to delete the figure

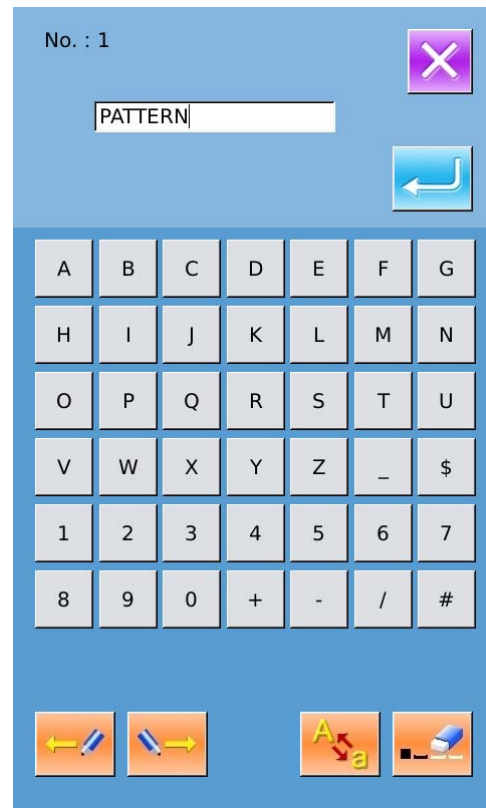

2.6 Winding

① Install the shuttle core

Fit the shuttle core fully onto the winder shaft. (as shown in the figure in right)

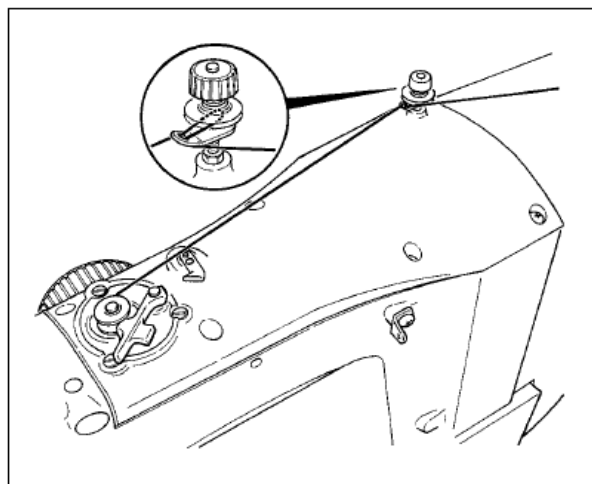

② Display the bottom thread winding screen

Press  in the data input interface (orange) or the sewing interface (blue), and then the winding interface will be displayed (as shown in the right figure)

③ Start Winding

Step the start pedal, and then the sewing machine runs and starts winding bottom thread.

④ Stop the sewing machine

Press STOP button  to stop the sewing machine. The system will return to the normal mode. By the way, in the bottom-thread winding mode, stepping the start pedal will stop the machine at this mode. Step the pedal again to resume winding. This function can be used at winding several shuttle cores.

Note: After user turns on the power, or changes to main controller input, the system will not perform the winding action. Please set the pattern

and press the  to display the sewing interface.

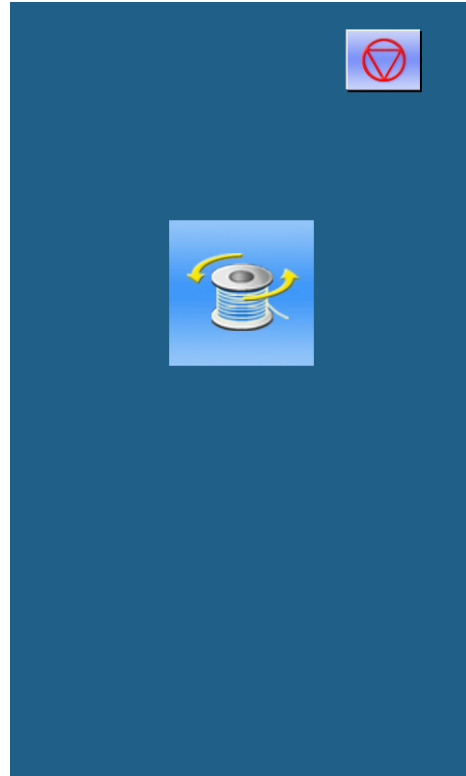

2.7 Pattern Selection

① Enter Pattern Selection Interface

In the data input interface (as shown in right), click Sewing Shape (A) to enter the interface for selecting patterns.

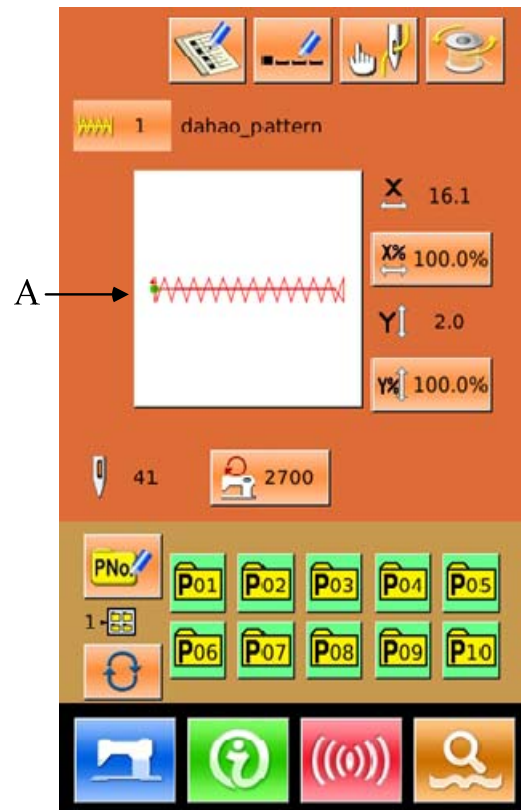

The upper area of the pattern selection interface is the sewing shape of the current pattern. Below that it is the number of the registered pattern.

: Preview the pattern

: Input the number to inquire pattern

: Delete the pattern

Click button A to shift between the basic patterns and user patterns, if the system has the normal patterns

② Pattern Selection

If the patterns are the basic patterns, 4 pattern numbers can be displayed in one page; for the user patterns, 20 pattern numbers can be displayed in one page. For the basic pattern, at each pattern

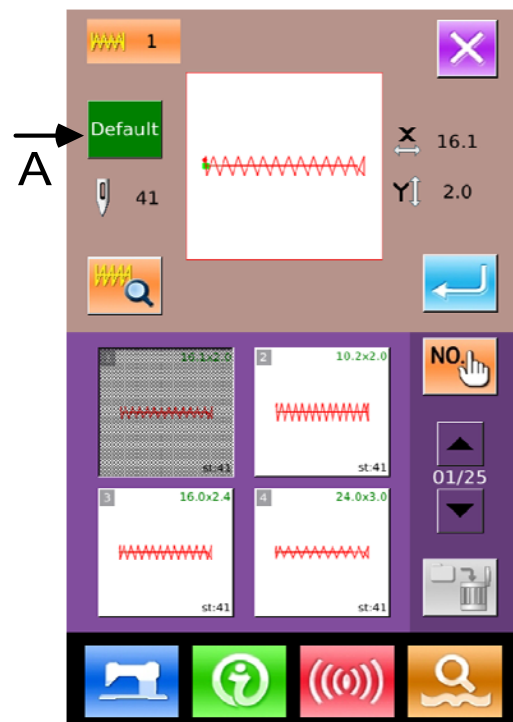

number, the system will also display the shape and x/y range of the pattern. For the user patterns, only the pattern number will be displayed. Select the registered pattern number. Then the system will display the content of that pattern in upper area. At this moment, press  to finish the selection.

③ Pattern Inquiry

Press  to activate the interface of Pattern Inquiry, input the number of pattern via the number keys

④ Pattern Deletion

Select the registered pattern and then press , the pattern will be deleted. However, the patterns registered to P pattern can't be deleted

Note: Patterns are divided into basic pattern and normal pattern. The basic patterns are the default patterns, which can't be deleted. The normal patterns are the patterns made, copied or input by user, which can be deleted or modified.

⑤ Pattern Preview

Press  to preview the current pattern in full screen (White Background).

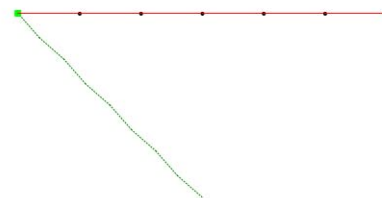
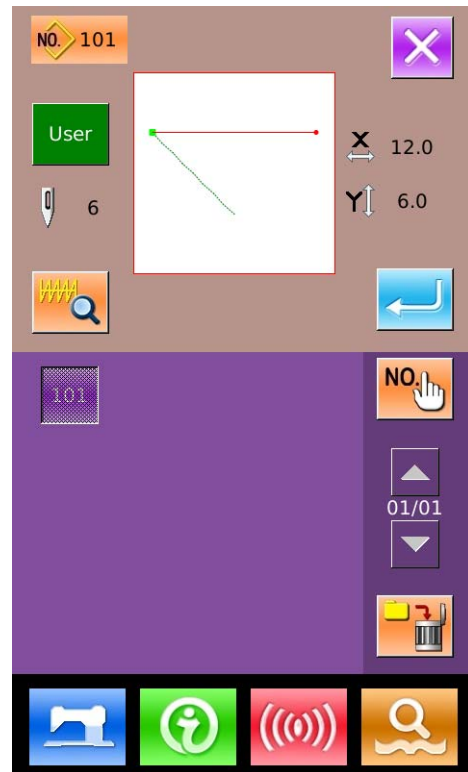

2.8 Sewing Data Setting

① Enter Interface for Setting the Sewing Data

In data input interface, pressing button A, B or C can enter the scale rate setting interface and speed limitation interface respectively.

| | Item | Input Range | Default Value |
|---|--------------|---|---------------|
| A | X Scale Rate | 1.0~400.0% | 100.0% |
| B | Y Scale Rate | 1.0~400.0% | 100.0% |
| C | Max Speed | 400~2700rpm (Different among different models) | 2700rpm |

Note 1: Parameter U64 can shift between the setting of scale rate and the setting of actual size.

Note 2: The range and the default value of Max speed are affected by the parameter U01.

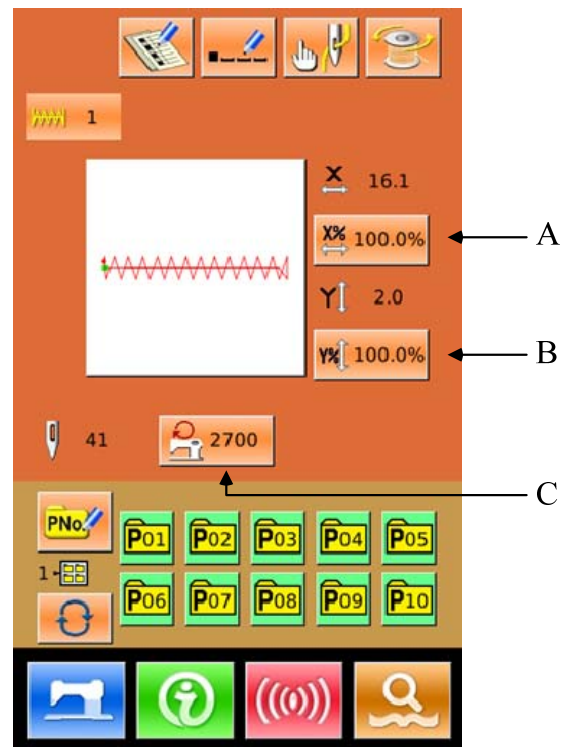

② Set Scale Rate

The right figure is the interface for setting the scale rate. The upper part is for setting X scale rate, while the lower part is for setting the Y scale rate.

- A: X Actual Size
- B: X Scale Rate
- C: Y Actual Size
- D: Y Scale Rate

Use **0** ~ **9** and number keyboard or

↑ & **↓** to input the value. The input value will be inserted to the first place of the figure. The number input at before will be moved forwards.

Press **↩** to finish the operation and return to data input interface.

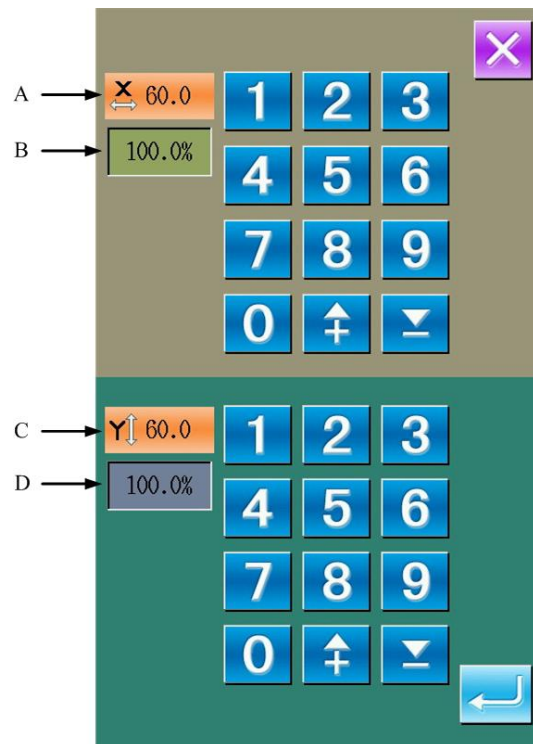

③ Set Max Speed

The operation is same to that in above.

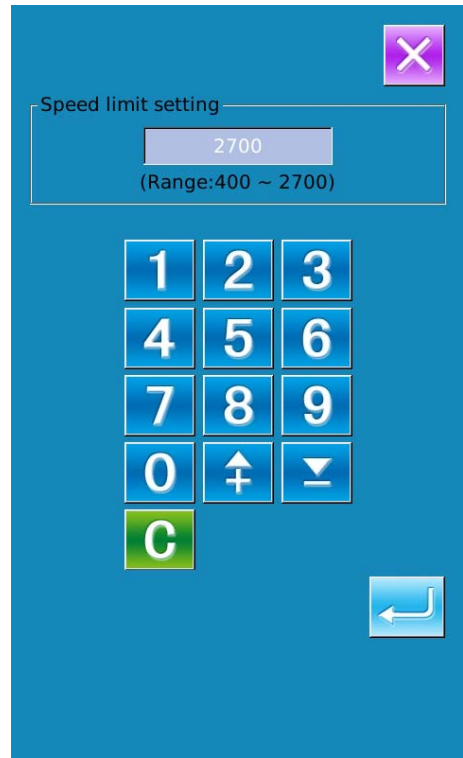





2.9 P Pattern Registration

① Enter P Pattern Registration Interface

In data input interface, press  to enter the interface of P Pattern Registration (shown as the right figure)

② Input P Pattern Number

Use  ~  and number keyboard or  &  to input the number for registration. If the input number has been registered in the system before, the interface will display the shape and relating data of that registered pattern. In this situation, the new pattern can not be registered with this number

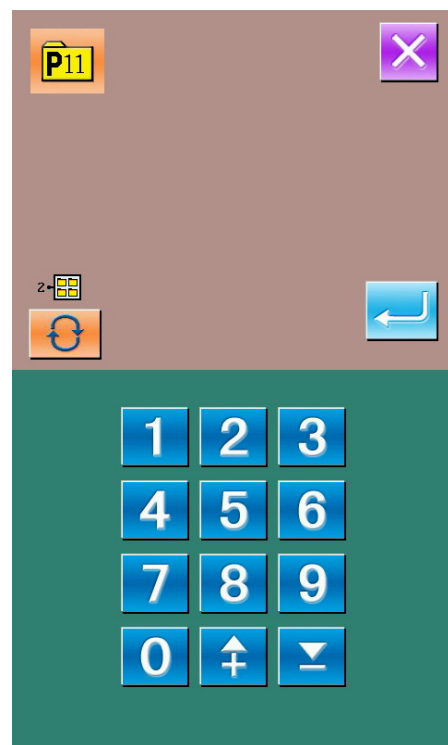

③ Select File Folder Number

P pattern number can be registered into 5 file folders, and each folder can contain 10 P patterns at most. Press  to select folder in order.

④ Confirm Pattern Number

Press  to finish the Registration of P Pattern and return to the input interface of P Pattern Data

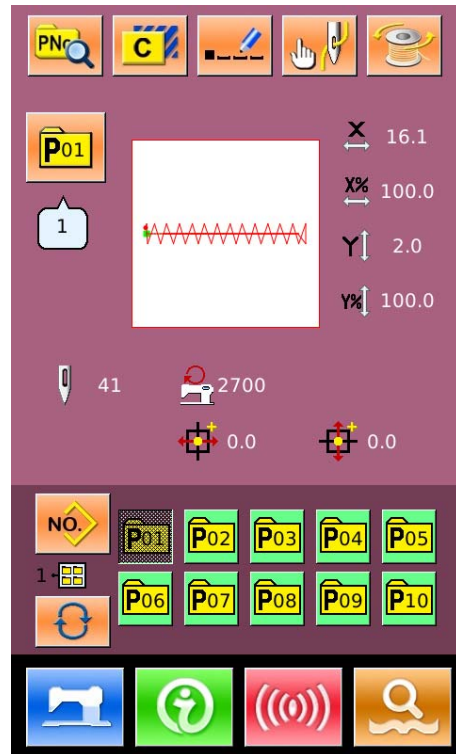





2.10 Trial Sewing

① Display the interface of sewing

At data input interface, press , the background of screen will change to blue, and the system enters the interface for sewing



② Display of Trial Sewing

In the sewing interface. Press  to enter the trial sewing interface (As Shown at Right):

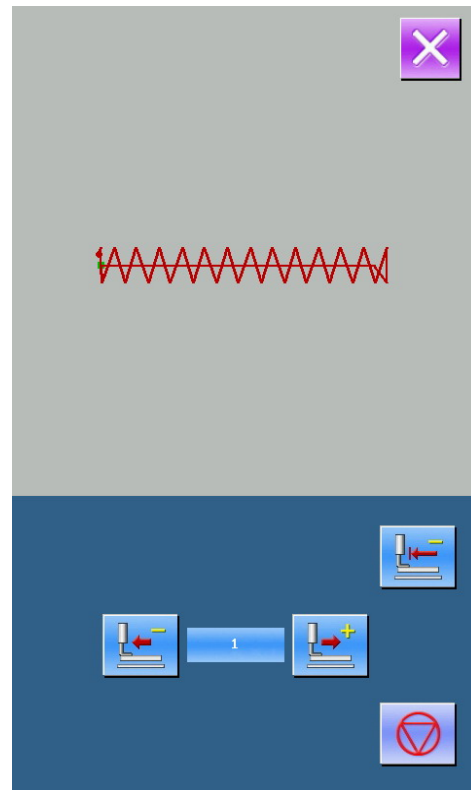
-  : Return to Origin
-  : Return
-  : Forward
-  : Stop





③ Start Trial Sewing

Step the pedal to lower the presser. Use  and  to confirm the shape. After user holds that button for a while and then release it, the presser will still keep moving. At this moment, please press  to stop it



Press  to have needle return to origin. And the system will return to the sewing interface.

④ End Trial Sewing

Press  to quit the trial sewing interface and return to sewing interface. When the pattern is not at the start position or end position, user can carry out sewing in the middle by stepping the pedal. For quit, please press  and turn off the activated interface. Then the sewing interface will displayed and the system returns to the sewing start position.

2.11 Counter Operation



① Display the counter interface

In the sewing interface, press  (), the interface of counter setting comes out.

 : Sewing Counter

 : No. of Pieces Counter

② Selection and Setting of Counter

The user can set the type of counter by choosing  and , and set the value of counter

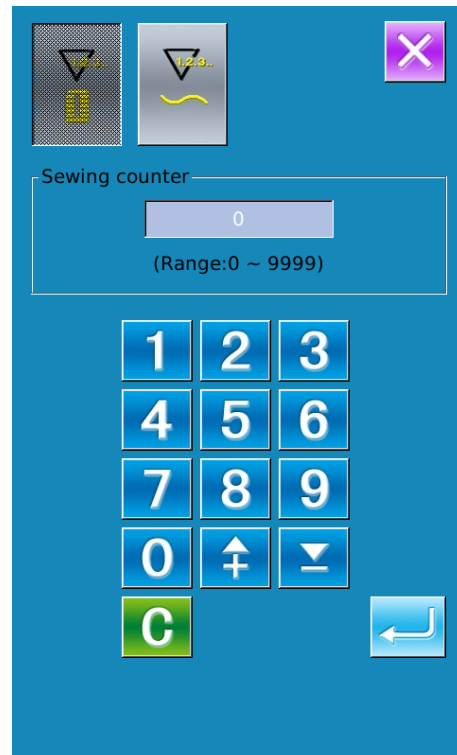

2.12 Emergency Stop

By setting parameter U31 to select pause method:
User can select among Invalidity, Panel and EXT
to set the pause method.

When the pause button is pressed, the interface

will display the .

① Release the Error

Press Pause button at sewing to stop sewing
machine. At this moment, the error interface is
displayed, which hints user the pause key is

pressed. At this moment, press  to release
the error.

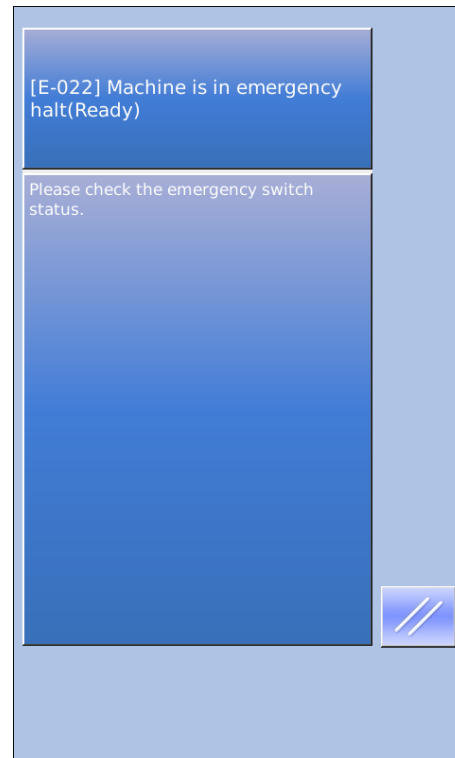

② Trimming

Press  to cut thread and enter the
procedure setting interface.

**Note: When the Parameter U97 is set at Auto
Trim at Pause, the system will enter
procedure setting directly.**





② Set procedure and adjust the presser to re-sewing position

Press  to enter procedure setting interface.

 : Backward feeding

 : Forward feeding

 : Return to Origin

Press  or  to move presser to the re-sewing position

③ Restart sewing

Step pedal too restart sewing.

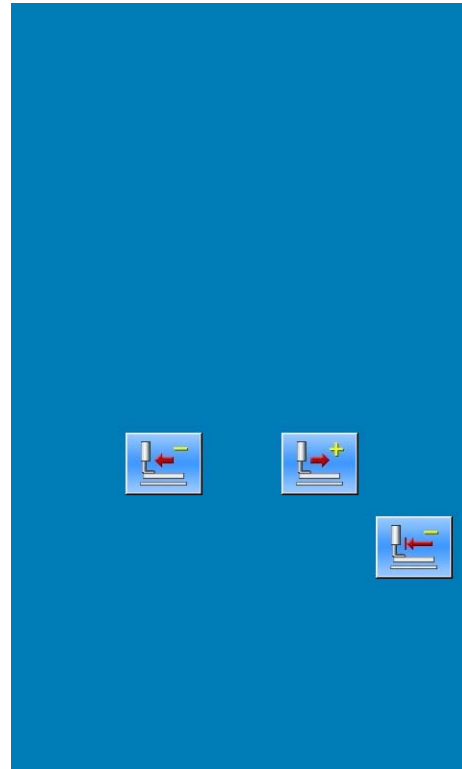

3 Operations on Prompt (P) Pattern

3.1 P Pattern Data Input

The Prompt pattern is called P Pattern for short, which contains a normal pattern and its relating sewing parameters, like X scale rate, Y scale rate, speed limitation and so on. If selecting a P pattern, user will get rid of the trouble for setting the parameters of the pattern at each time sewing

In the right picture, is shown the P Pattern Data Input Interface.

50 P patterns can be registered at most.

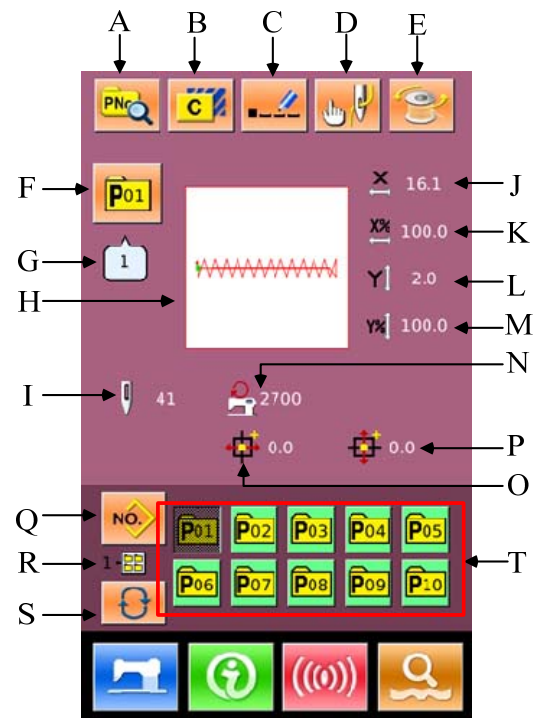

List of Function Keys:

| No. | Functions | Content |
|-----|-----------------------------|---|
| A | P Pattern Edition | Edit the content of P pattern |
| B | P Pattern Copy | Copy the content of existing P pattern to an empty pattern number. |
| C | Pattern Naming | 14 figures can be inputted at most. |
| D | Threading | Presser it to lower the presser. |
| E | Winding | Wind the thread with a press on  |
| F | P Pattern Number Display | Display the number of the selected pattern. |
| G | Sewing Shape Number Display | Display the number of the normal pattern quoted in the existing P pattern. |
| H | Sewing Shape Selection | Display the sewing shape of the current pattern |

| No. | Functions | Content |
|------------|--|---|
| I | Pattern Stitch Number Display | Display the stitch number of the currently selected pattern. |
| J | X Actual Size Display | Display the X actual size of current pattern |
| K | X Scale Rate Setting | Display the X scale rate of current pattern |
| L | Y Actual Size Display | Display the Y actual size of current pattern |
| M | Y Scale Rate Setting | Display the Y scale rate of current pattern |
| N | Max Speed Limitation | Display the Max Speed |
| O | X Travel Amount Display | Display the X travel amount of the currently selected pattern |
| P | Y Travel Amount Display | Display the Y travel amount of the currently selected pattern |
| Q | Return to Normal Pattern Data Input | Return to the interface for inputting normal pattern data |
| R | P Pattern File Folder Display | Display the file folder number of the current P pattern |
| S | P Pattern File Folder Selection | Shift the file folder number of P pattern in sequence. |
| T | P Pattern Selection | Display the registered P pattern |

3.2 P Pattern Edition

① Have Access to P Pattern Edition Interface

Press  to have access to P Pattern Edition Interface (as shown at the right picture)

② Change the Item Data

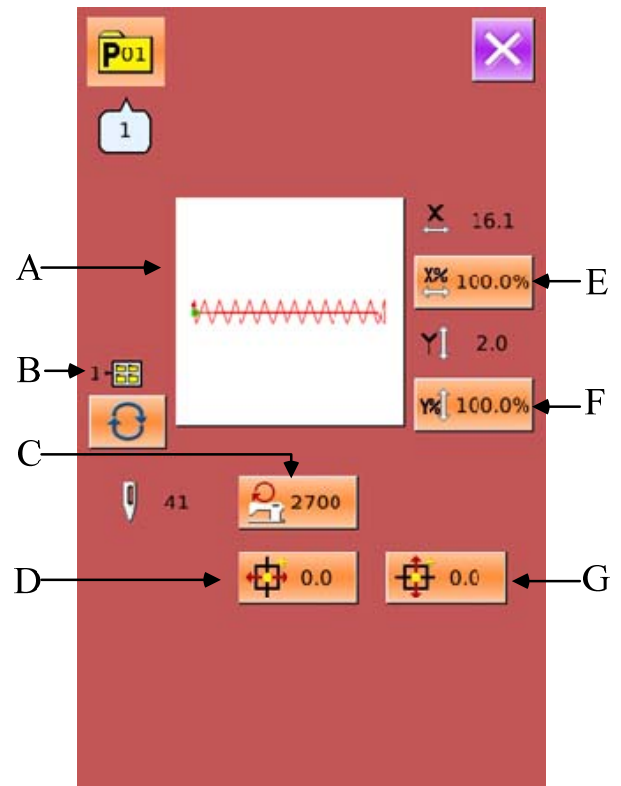

Select the item for changing and set the value.

| | Item | Range | Default Value |
|---|----------------------|--------------|---------------|
| A | Sewing Shape | | |
| B | File Folder Number | 1~5 | |
| C | Max Speed Limitation | 200~3000rpm | 3000rpm |
| D | X Travel Amount | -30.0~30.0mm | 0 |
| E | X Scale Rate | 1.0~400.0% | 100.0% |
| F | Y Scale Rate | 1.0~400.0% | 100.0% |
| G | Y Travel Amount | -30.0~30.0mm | 0 |



③ Confirm the Change of Data

Take the edition of “X Travel Amount” as example:

With  ~  and keyboard or ,

user can input the value. Press  to finish the operation.



: The Positive Figure;



: The Minus Figure

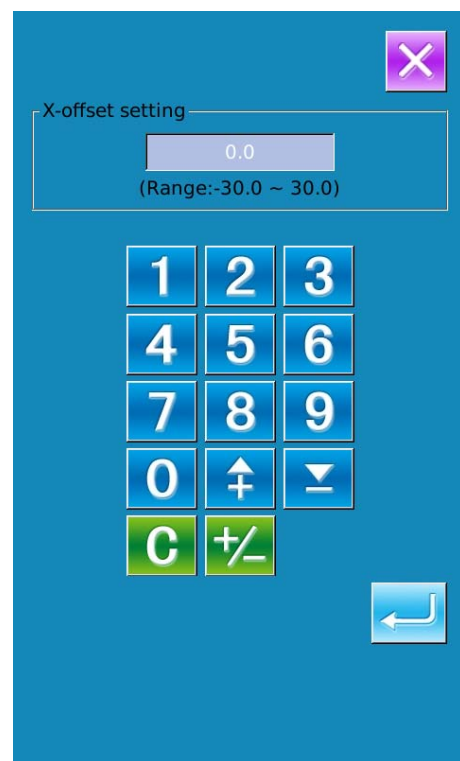

④ Quit the Edition

Press  to close P Pattern Edition Interface and the system will return to the Interface for Inputting Sewing Data.



3.3 P Pattern Copy

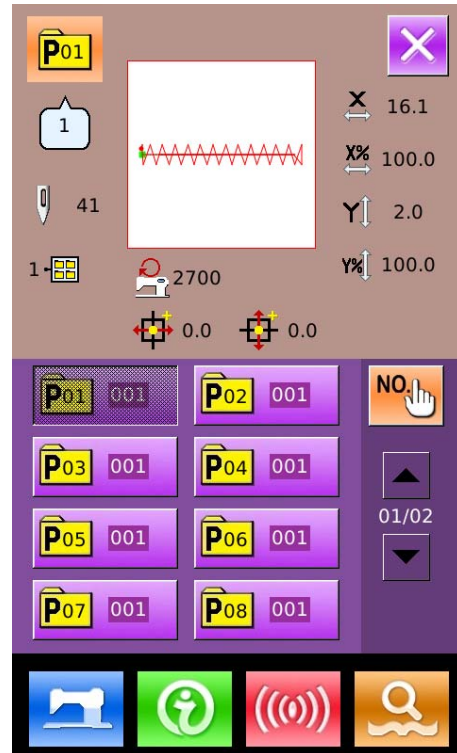

① Select a Pattern to Be Copied

Press  to have access to P Pattern Copy Interface (as shown at right picture). Select the number of the pattern that needs copying among the registered ones, and then press .



② Input newly Registered Pattern Number

The Pattern to be copied is displayed at the upper side of the interface. By using number keys, user can select the unregistered pattern number. The registered pattern number is unable to be registered again.

When pressing , user can select the file folder for saving. Press  to finish the operations for copying the pattern, and the system will return to the Interface for Copying P Pattern

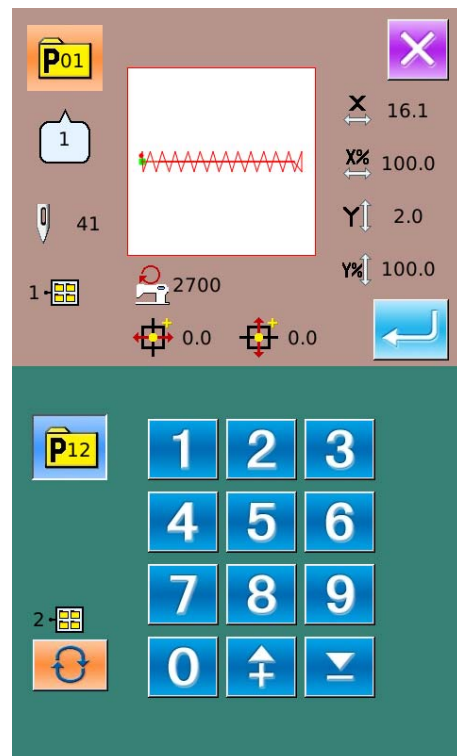

3.4 P Pattern Selection

① Have Access to P Pattern Selection

Interface

As shown in right picture, user can press Key (A) to have access to P Pattern Selection Interface

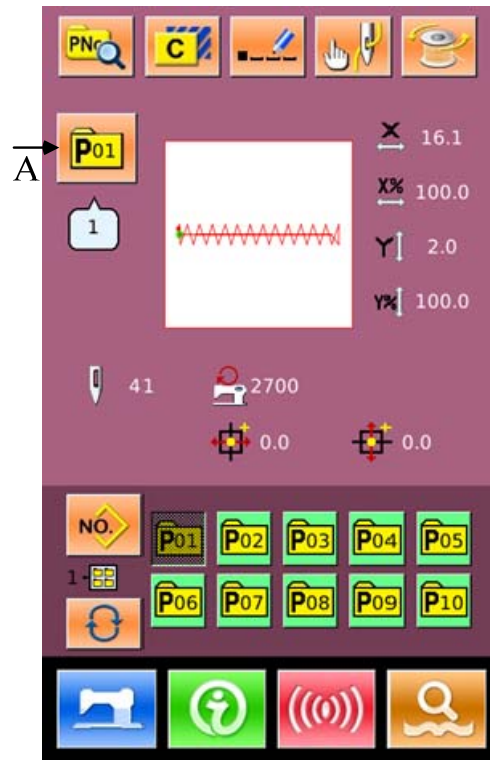

② Select Pattern Number

The relating information of the currently selected pattern is displayed at the upper side of the interface.

When user presses  to shift the status of concealing the file folder number, the entire registered P patterns can be displayed.

③ Confirm the Selection of Pattern

The operation is same to that of normal pattern selection. Press  to end the selection.

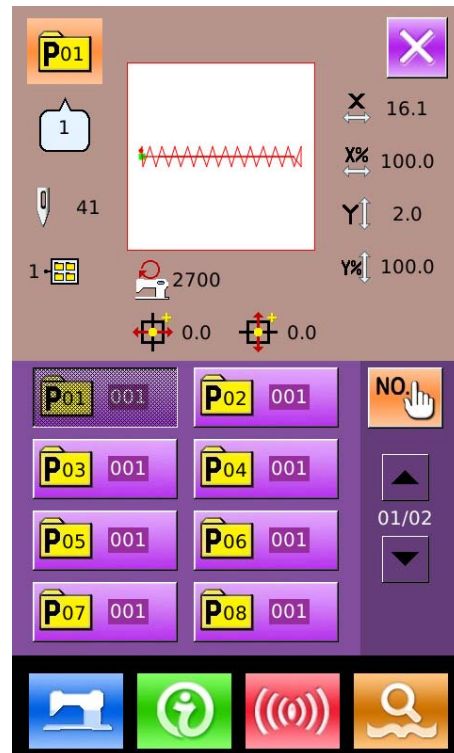

3.5 P Pattern Sewing:

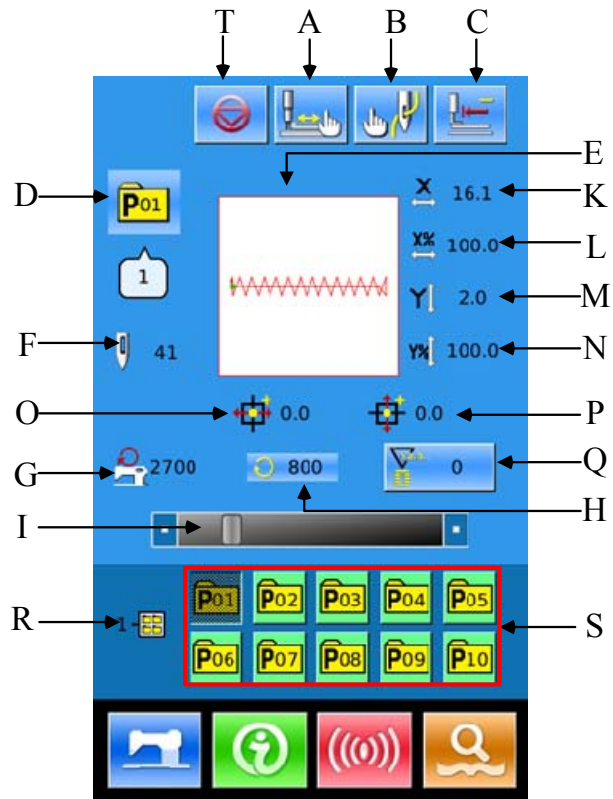

At the Interface for Inputting P Pattern

Data, User can press  to have access to the Sewing Interface (as shown in right).



List of Functions Keys:

| No. | Functions | Content |
|-----|-------------------------------|---|
| A | Trial Sewing | Press it to have access to Trial Sewing Interface, where user can determine the shape of f pattern. |
| B | Threading | Press it to lower the presser. |
| C | Return to Origin | Press it to have the presser return to the start point. |
| D | P Pattern Number Display | Display the number of the currently selected pattern. |
| E | Sewing Shape Number Display | Display the number of the normal pattern quoted in the existing P pattern. |
| F | Pattern Stitch Number Display | Display the sewing stitch number of the currently selected pattern |
| G | Max Speed Limitation | Display the Max Speed Limitation |
| H | Sewing Speed Display | Display the current sewing speed |

| No. | Functions | Content |
|-----|--------------------------------------|---|
| I | Sewing Speed Setting | Change the sewing speed |
| K | X Actual Size Display | Display the X actual size of current pattern |
| L | X Scale Rate Setting | Display the X scale rate of current pattern |
| M | Y Actual Size Display | Display the Y actual size of current pattern |
| N | Y Scale Rate Setting | Display the Y scale rate of current pattern |
| O | X Travel Amount Display | Display the X travel amount of the currently selected pattern |
| P | Y Travel Amount Display | Display the Y travel amount of the currently selected pattern |
| Q | Counter Setting | Press it to set the type and the present value of counter.  : Sewing Counter  : No. Pieces Counter |
| R | P Pattern File Folder Number Display | Display the file folder number of the current P pattern |
| S | P Pattern Selection | Display the registered P pattern |
| T | Pause | Press it to stop machine. It is controlled by parameter U31. When user selects Panel at that parameter, the screen will display the pause key. Other options will not display that button on screen. |

4 Operations on Combination (C) Pattern

4.1 C Pattern Data Input

The combination pattern, called as C pattern for short, consists of a group of P patterns, which can contain 50 sub-patterns at most. In this model, 50 C patterns can be registered into the system at most.

For having access to the Interface of Combination Pattern Data Input (as shown at right), please refer to the content in [8.8 Change Sewing Type]

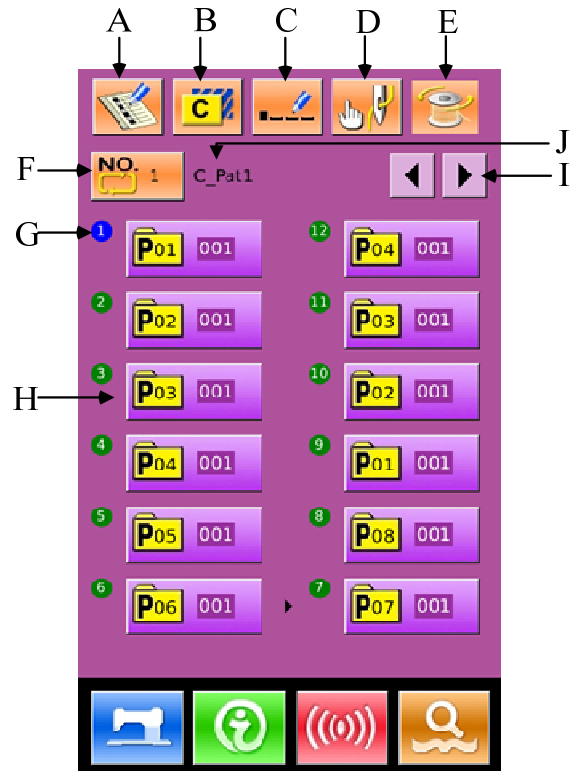

List of Function Keys:

| No. | Function | Contents |
|-----|----------------------------|--|
| A | C Pattern Registration | Register a new C pattern. |
| B | C Pattern Copy | Copy the content of Current C pattern to an empty pattern number. |
| C | Pattern Naming | 14 figures can be inputted at most. |
| D | Threading | Press it to lower the presser. |
| E | Winding | Wind the thread with a press on  . |
| F | C Pattern Number Selection | The number of the currently selected pattern is displayed on the button. Press it to have access to the C Pattern Selection Interface. |
| G | Sewing Sequence | Display the sewing sequence of the currently selected pattern. The |

| No. | Function | Contents |
|-----|---------------------------|---|
| | Display | pattern with a blue marks is the initial sewing pattern. |
| H | C Pattern Shape Selection | Press it to have access to C Pattern Edition Interface. Operator can select a P pattern to input. |
| I | Page | 30 C patterns can be registered at most, and 6 C patterns can be displayed on each page at most. |
| J | C Pattern Name | Display the Name of C pattern. |

4.2 C Pattern Edition

① Have Access to C Pattern Edition Interface

At Interface of C Pattern Data Input, user can press A to have access to C Pattern Edition Interface.

In initial status, because no sewing shape is registered to P pattern, the first one is displayed as blank.

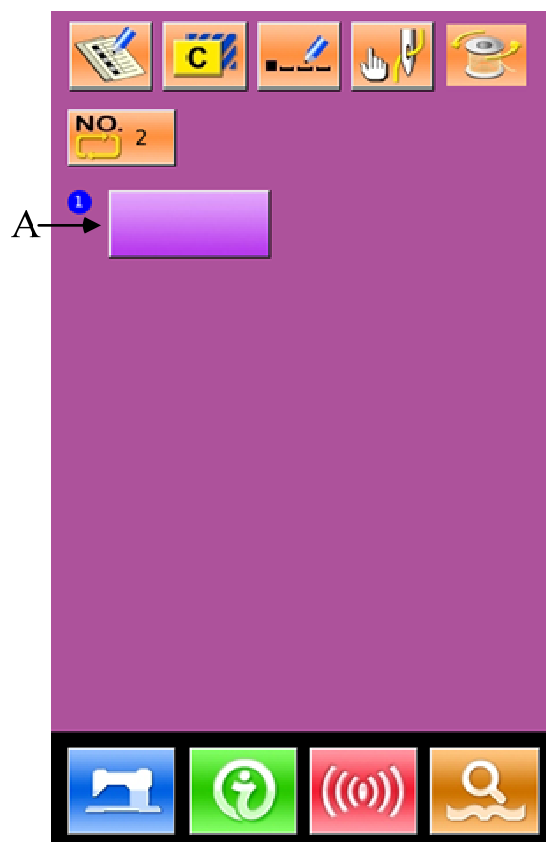

② Select Shape

At C Pattern Edition Interface (the right figure), user can select the P Pattern (B)

for registration and then press  to finish the selection.

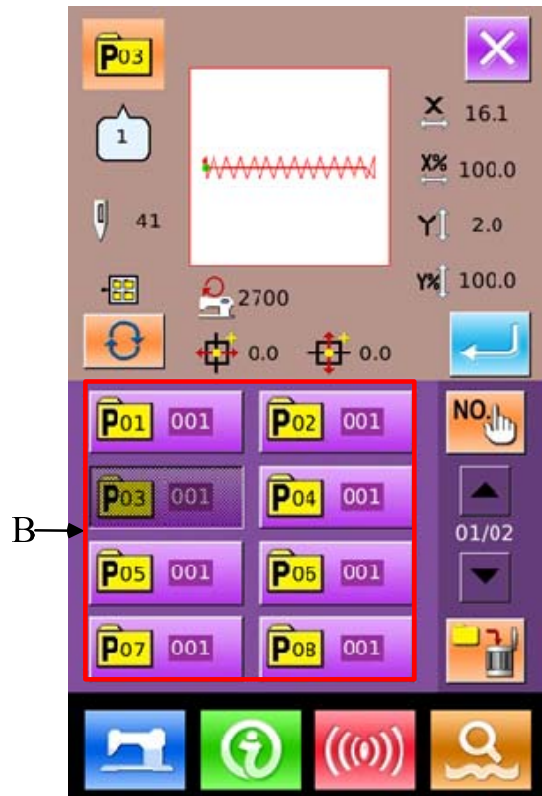

③ Repeat the Registration

When the 1st pattern is registered, the Selection Key (C) for the 2nd pattern is displayed. Repeat the operations at above so as to register other patterns.

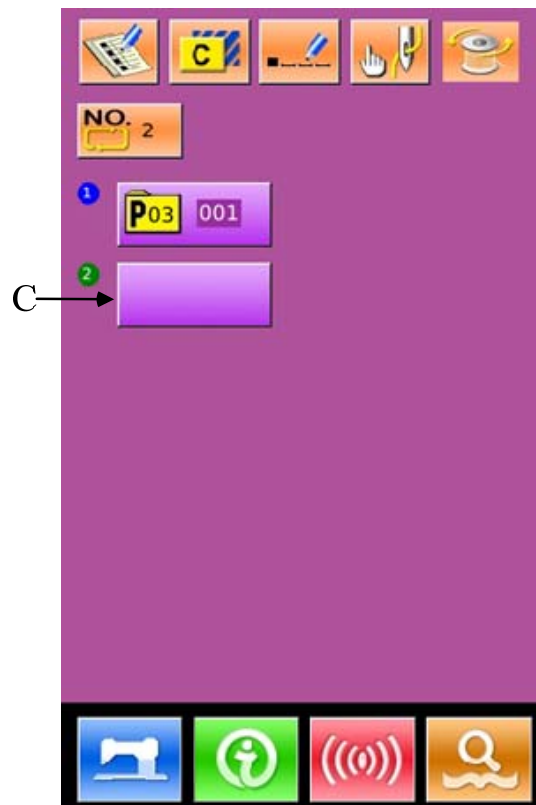

4.3 C Pattern Selection

① Have Access to C Pattern Selection

Interface

As shown on the right picture, user can have access to C Pattern Selection Interface by pressing Figure A.

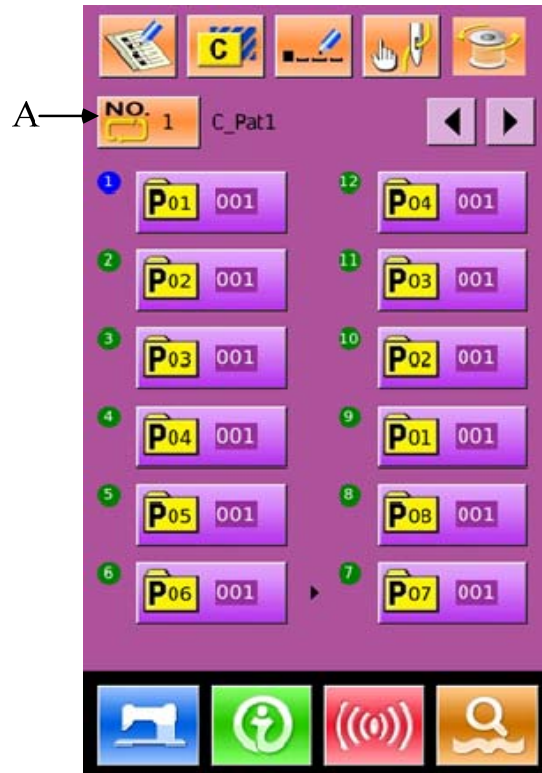

② Select C Pattern Number

At C Pattern Selection Interface (the right figure), user can press B to change the data information of P patterns within the current C pattern in sequence.

Confirm the number of the needed C pattern

(C), and then press  to finish selection

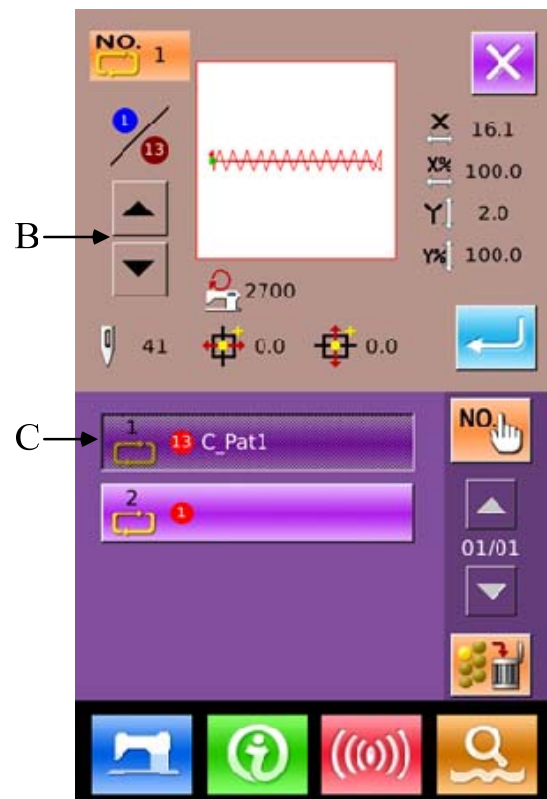

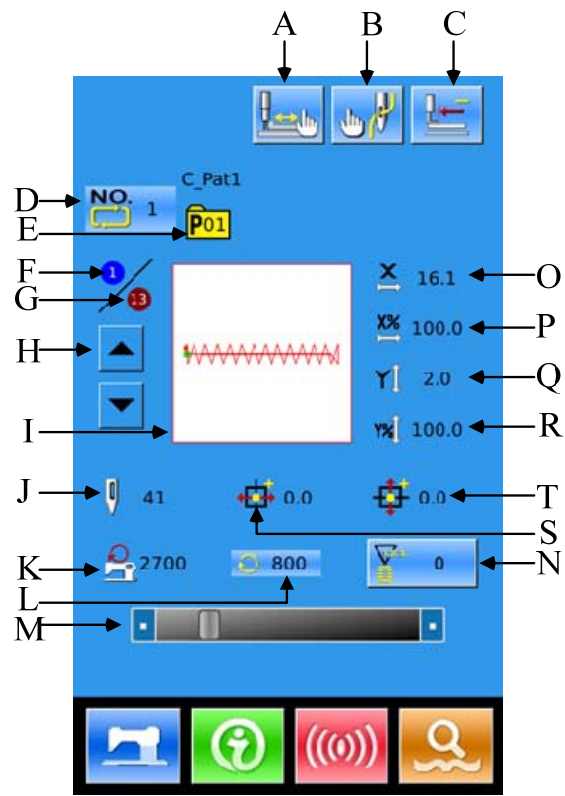

4.4 C Pattern Sewing

At Interface of C Pattern Data Input, user can press  to have access to Sewing Interface (as shown in right picture).



List of Function Keys:

| No. | Functions | Contents |
|-----|----------------------------------|---|
| A | Trial Sewing | Press it to have access to Trial Sewing Interface, where user can determine the shape of f pattern. |
| B | Threading | Press it to lower the presser. |
| C | Return to Origin | Press it to have the presser return to the start point. |
| D | C Pattern Naming | Display the name of current pattern. |
| E | Sewing Shape Number Display | Display the number of the sewing shape registered under the current C pattern |
| F | Sewing Sequence Display | Display the sewing sequence number at current pattern |
| G | Total Number Display | Display the total number of sub-patterns registered in the current C pattern |
| H | Sewing Sequence Forward/Backward | Select the previous or next shape for sewing. |
| I | Pattern Shape | Display the shape registered at current sewing |

| No. | Functions | Contents |
|-----|------------------------------|--|
| J | Patten Stitch Number Display | Display the stitch number of the shape registered at current C pattern. |
| K | Max Speed Limitation Display | Display the Max speed at sewing this shape |
| L | Sewing Speed Display | Display current sewing speed |
| M | Sewing Speed Setting | Enable to change sewing speed |
| N | Counter Setting | Press it to set the type and the present value of counter.  : Sewing Counter  : No. Pieces Counter |
| O | X Actual Size Display | Display the actual size of the selected pattern in X direction. |
| P | X Scale Rate Setting | Display the X scale rate of the selected pattern. |
| Q | Y Actual Size Display | Display the actual size of the selected pattern in Y direction. |
| R | Y Scale Rate Setting | Display the Y scale rate of the selected pattern. |
| S | X Travel Amount Display | Display the X travel amount of the currently selected pattern |
| T | Y Travel Amount Display | Display the Y travel amount of the currently selected pattern |

5 Pattern Edition

5.1 Have Access to Pattern Edition Mode

User can press  to shift the data input interface to the Mode Selection Interface (as shown at right picture), where user can make some detailed settings and editions.

For the detailed operations and settings at Mode Selection Interface, please refer to【8 Mode and Parameter Setting】.

Press  to shift with .

 : Sewing Mode

 : Edition Mode

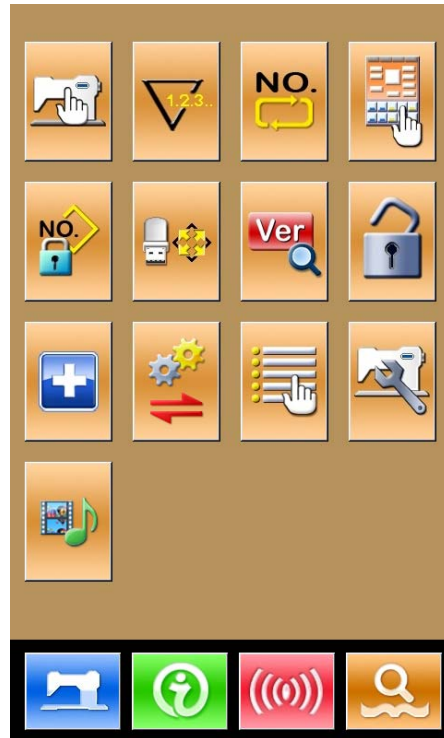

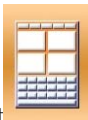

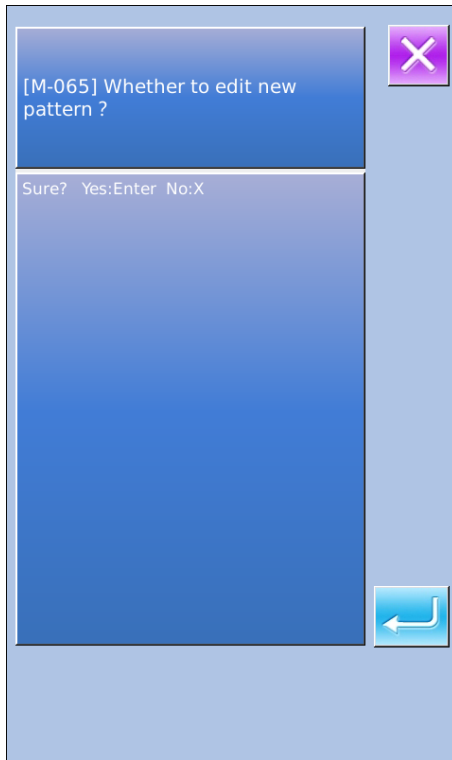



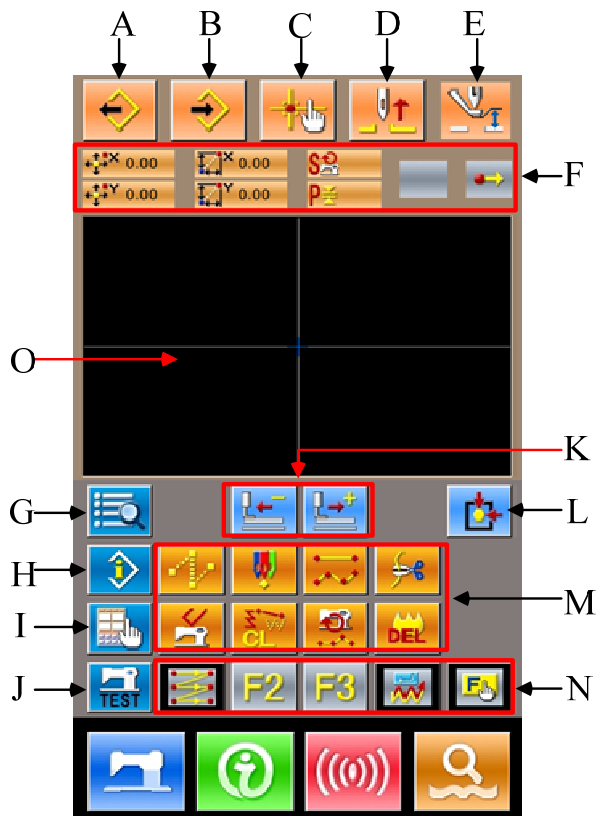



Select , At this moment, the system will ask user whether to have access to Pattern Edition Interface.



Press  to have access to Standard Interface for Pattern Edition, as shown in the right picture:









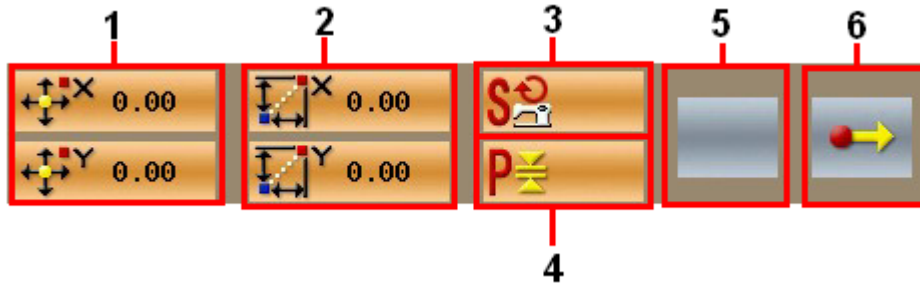

List of Function Keys:

| No. | Function | Contents |
|-----|-------------------------------------|--|
| A | Load Pattern | Display the Pattern Loading Interface |
| B | Input Pattern | Display the Pattern Input Interface |
| C | Needle-entry Point Inquiry | Promptly locate the needle entry point; when editing the patterns, user can input the coordinates of the sewing point directly. |
| D | Lift needle | Make needle return to the highest point |
| E | Move Intermediate Presser | Lift or lower the intermediate presser |
| F | Current Needle Position Information | Display the position information of needle at present |
| G | Code List | Display the entire available editing functions. Please refer to [List of Editing Functions] for details. |
| H | Information Display | Display the detailed information of the currently edited pattern |
| I | Display Setting | Enable wide-angle setting, needle entry point display setting and so on |
| J | Trial Sewing | Put the currently edited pattern through a trial sewing |
| K | Forward· Backward Feeding | Move one stitch from the current position (forwards  ; backwards ) |
| L | Return to Origin | Return the needle from current position to origin |
| M | Function Keys | Call the functions on the buttons directly |
| | | 1  : Empty feeding |
| | | 2  : Point Sewing |
| | | 3  : Normal Sewing |
| | | 4  : Thread-trimming |
| | | 5  : Cancellation of Mechanical Control Order |
| | | 6  : Element Deletion |
| | | 7  : Changes on Sewing Speed Section |
| | | 8  : Delete Current Pattern |

| No. | Function | Contents |
|-----|----------------------------|---|
| N | Hot Keys | By using Function of Selection and Setting (Function Code 112), user can distribute the needed functions to each button. After the distribution, the figure of that function is displayed in the corresponding key. |
| O | Pattern Shape Display Area | Display the pattern |



| No. | Item | Content |
|-----|-----------------------|---|
| 1 | Absolute Coordinate | The absolute coordinate of current needle position to the origin |
| 2 | Relating Coordinate | The relating coordinate of current needle position |
| 3 | Speed | The sewing speed or empty feeding speed of current point. |
| 4 | Interval | The length of current element stitch. (If the stitch is scaled, the value before the scaling will be displayed.) |
| 5 | Type of Element | Types of current elements. At setting sewing data, the system will displayed the element types, like jump feed  , broken line  , free curve  and so on). At setting the mechanical orders, the type of the control order will be displayed (like thread-trimming). |
| 6 | Types of Needle Entry | The types of the needle entry position: |
| | |  Start of Design: the start point (Origin) of a design. |
| | |  Middle Point of Element: the middle point of the element (neither the top point nor the ending point of the element). |
| | |  Top Point: the top point of a broken line. |
| | |  End Point of Element: the ending point of the element |
| | |  End Point of Pattern: the ending of pattern. |

5.2 Pattern Edition

Use Function of Pattern Edition to input the following pattern.

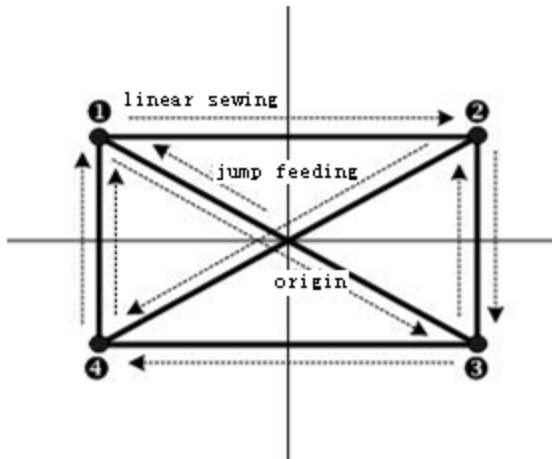

Input Point:

| | X (mm) | Y (mm) |
|---|--------|--------|
| ① | -40.00 | 25.00 |
| ② | 40.00 | 25.00 |
| ③ | 40.00 | -25.00 |
| ④ | -40.00 | -25.00 |

Input Order: It is shown as the dotted arrow in the left.

① Input of Empty Feeding



At Standard Interface for Pattern Edition,

user can press  to activate the Interface for Setting Empty Feeding: :

Note: user can also select “020: Empty Feeding” from function code list to enter the interface



After user presses , the Interface for Locating the Empty Feeding Position will be displayed:

At that Interface, user can use Direction Key (A) to move the icon (needle position) to the position with coordinate (0, 10). After pressing  for confirmation, user need press  to save the settings. After that, the system will return to the Standard Interface for Pattern Edition and display the empty Feeding stitch

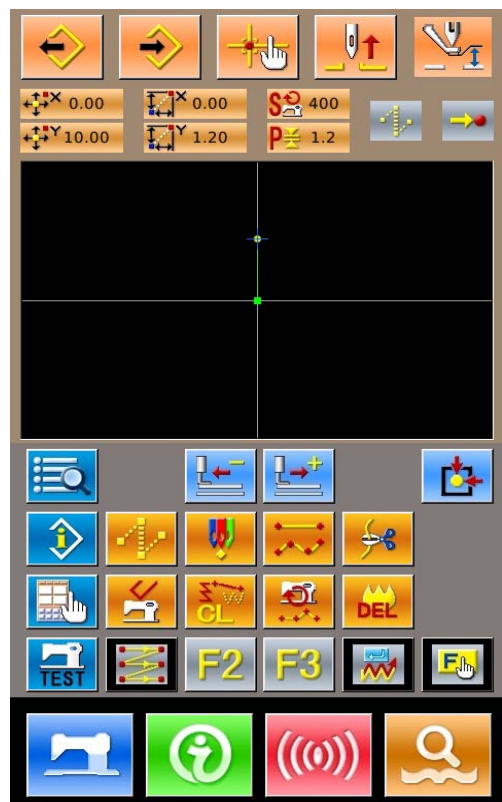
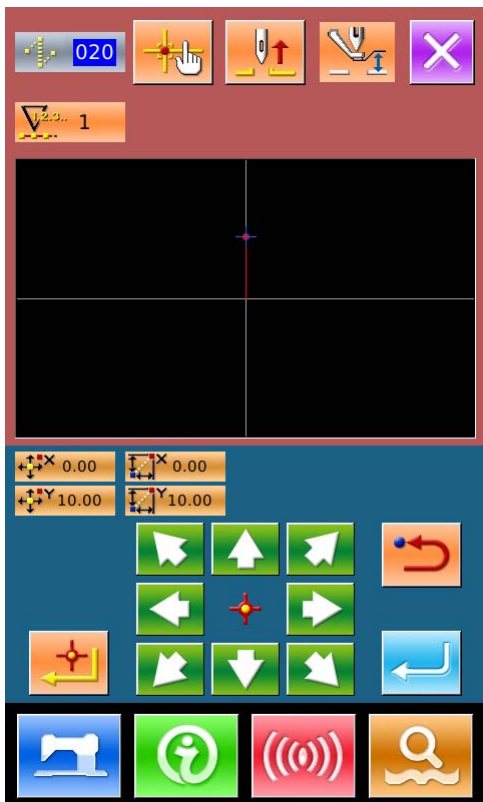
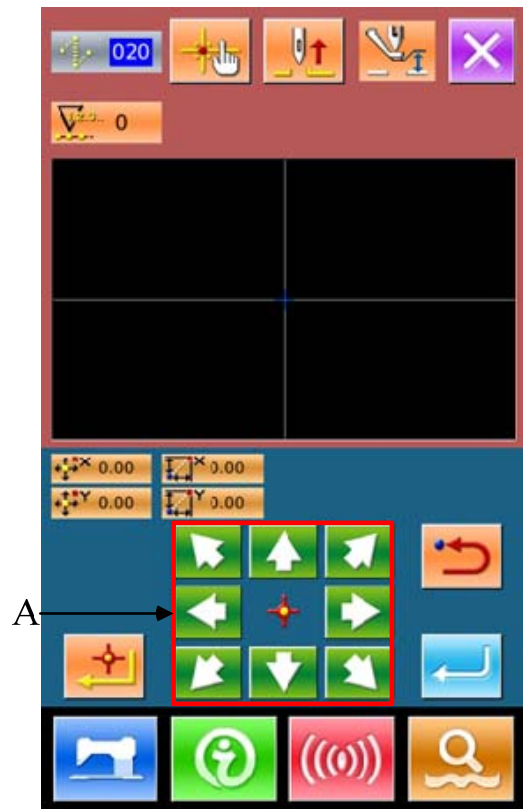

② Input of Linear Normal Sewing

At Function Code List, select “023 Linear Normal Sewing”, and then press  to have access to Interface for Setting Linear Normal Sewing





At Interface for Setting Linear Normal

Sewing, press **2.0mm** to have access to the interface for setting the sewing stitch length, as shown in right picture.

Press **3** and **0** in order to change the sewing length to “3.0”, and then press “ENTER” to save value and have the system return to the Interface for Setting Linear Normal Sewing

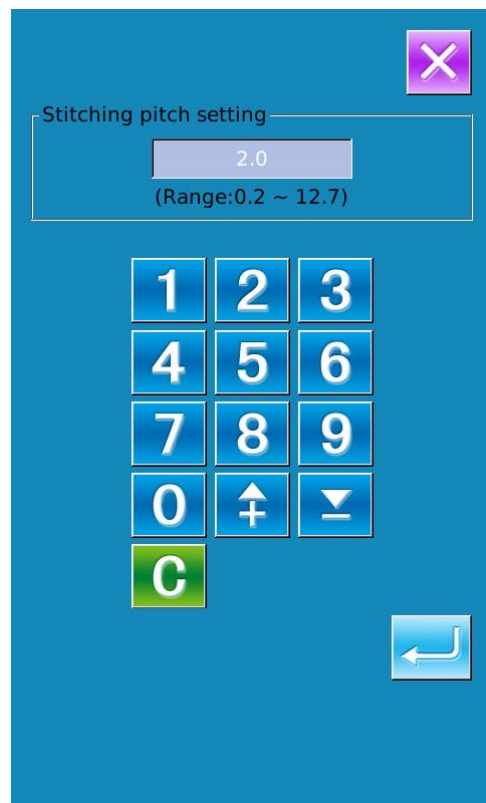
Note: Press **C** to clear the value.



After confirming the value “3.0mm” as the length of sewing stitch, user can press 

to have access to the Interface for Setting Linear Normal Sewing.

In that interface, user needs press Direction Keys to move the icon (where the needle

locates) from ① to ②, and then press 

Repeat the above operations to move the icon in the order

of ② → ③ → ④ → ① → ③ → ② → ④ → ①

, as shown in right picture.

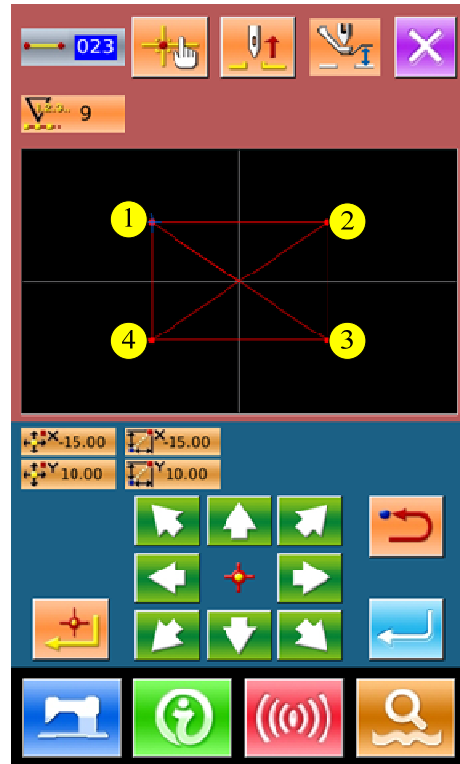

After confirming the pattern design, user can p



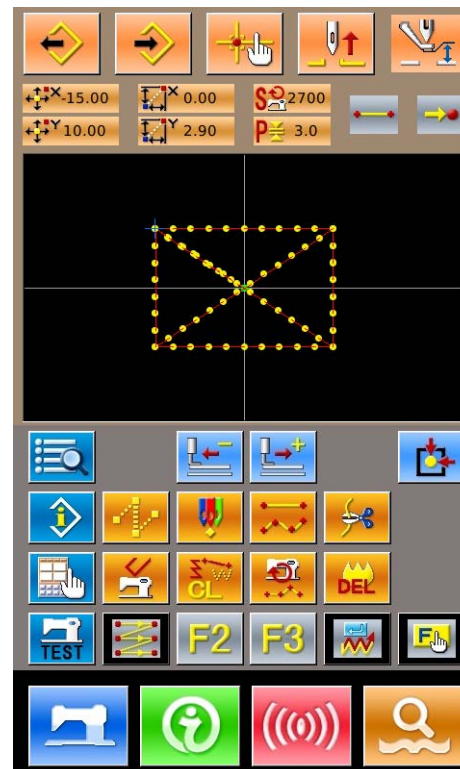

 to create the pattern data and have system return to Standard Interface for Pattern Edition where the pattern will be displayed.





③ Save Pattern

Press  to have access to Pattern Saving Interface to save the edited pattern, as shown in right pictures.

The system will set the pattern number automatically; user can also input the value with

 ~  and keyboard or  / . With

 and , user can select the location for saving the pattern. Both the U disk and the memory on operation panel will be available for saving the pattern.

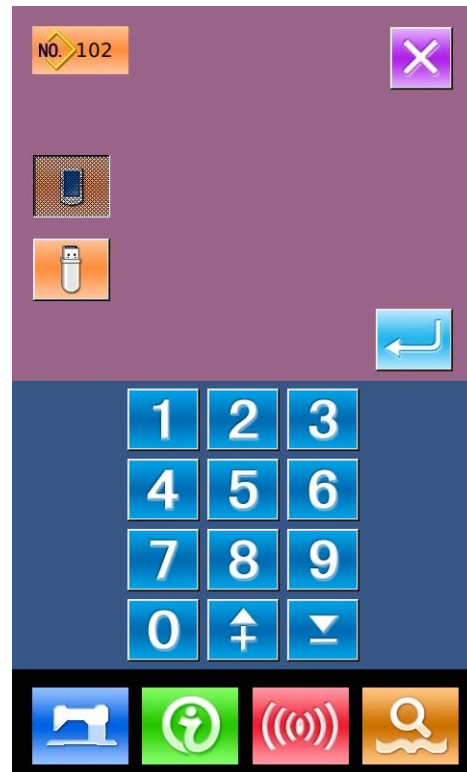

Press  to save pattern. Then the system will ask user whether to insert thread-trimming automatically, as shown at right picture.

Press  to add automatic thread-trimming action;

Press  to cancel the insertion of automatic thread-trimming action

After the operations, the system will return to Standard Interface for Pattern Edition.

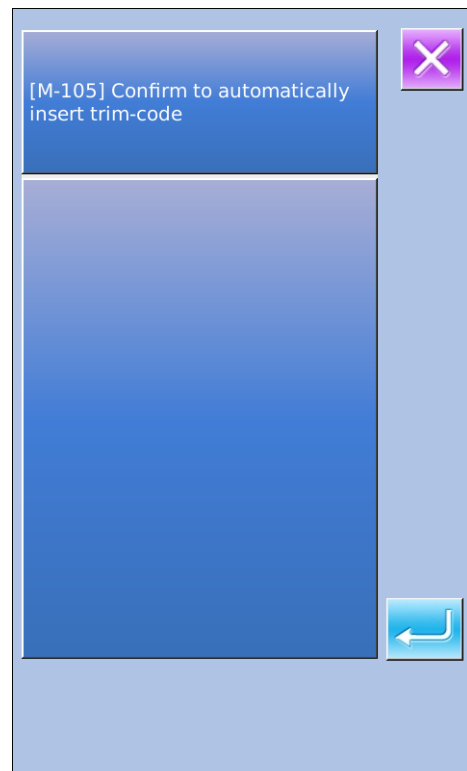

For the detailed operations and instructions of pattern edition, please refer to <SP510 Pattern-making Operation Manual>.

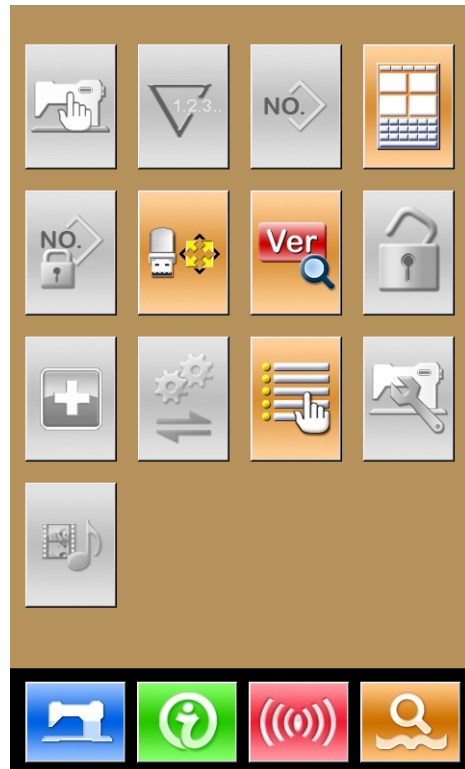

5.3 Quit Pattern Edition Mode

At Standard Interface for Pattern Edition, user can press  to have access to Mode Selection Interface, as shown at right picture.



Press  to shift to :

: Edition Mode

: Sewing Mode

Press  again to quit the Mode Selection Interface. At this moment, the system will ask user whether to return to Sewing Mode.

Pressing  is to quit from Pattern Edition Mode and to head for Sewing Mode.

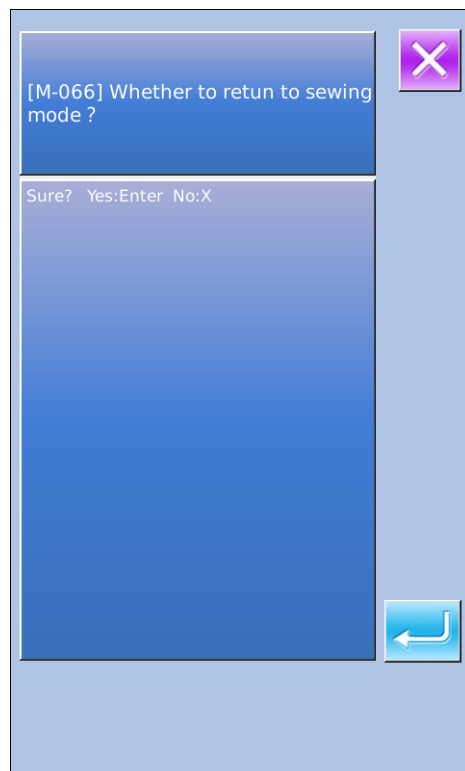

6 Information Functions

The Information Functions contain the following three functions:

- 1) The oil replacement (grease-up) time, needle replacement time, cleaning time, etc. can be specified and the warning notice can be performed after the lapse of the specified time.
- 2) Speed can be checked at a glance and the target achieving consciousness as a line or group is increased as well by the function to display the target output and the actual output.
- 3) Display the threading picture

6.1 Maintenance & Repair Information

① Display Information Interface

At Sewing Data Input Interface, user can Press Information Key (A) to activate the Information Interface.

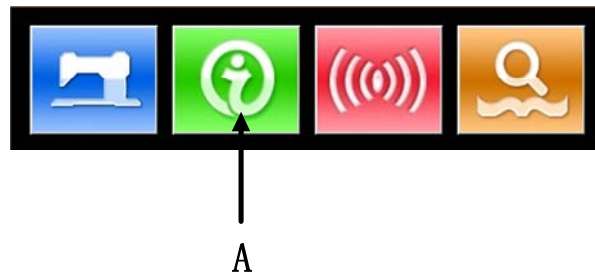

② Display Maintenance & Repair Interface

Please press  (B) at Information Interface

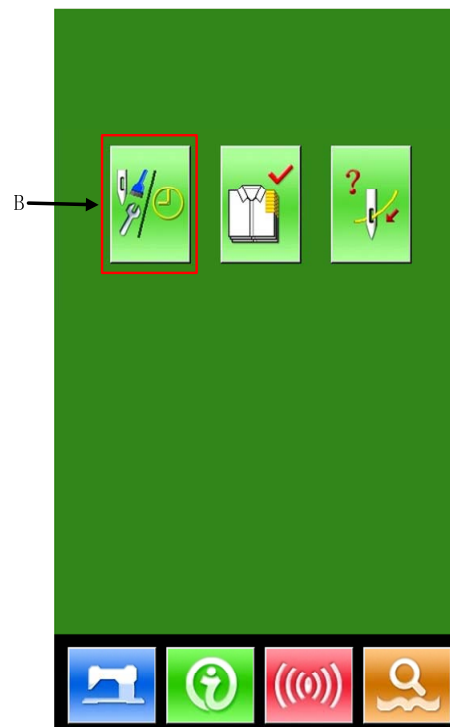

At Maintenance & Repair Interface, the system will display the information of the following three items.



: Needle Replacement (Thousand Stitches)\



: Cleaning Time (Hour)



: Oil Replacement Time (Hour)

The figure of each item is displayed on the button (C), the time interval for the repair notice is displayed at (D), and the time left to the replacement is displayed at (E)

Additionally, the time left to the replacement can be cleared by users.

Press  to quit to information interface.

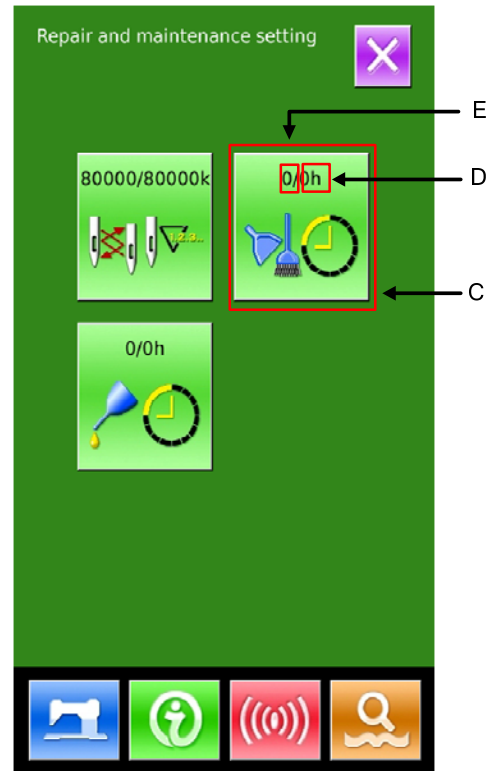

6.2 Input Time for Maintenance & Repair

① Display Information Interface (Maintenance Level)

At Interface for Inputting Sewing Data, user can hold the Information Key (A) for about 3 seconds to activate the Information Interface (Maintenance Level).

At that level, there are 6 buttons displayed on the interface

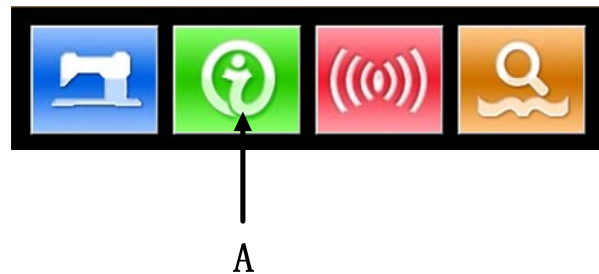

② **Information Interface**

At Maintenance level, there are 6 functions displayed as below:

-  : Maintenance & Repair
-  : Production Control
-  : Threading
-  : Alarm Record
-  : Running Records
-  : Periodical Password

Please press Maintenance & Repair

Information Key  (B) to activate the interface.

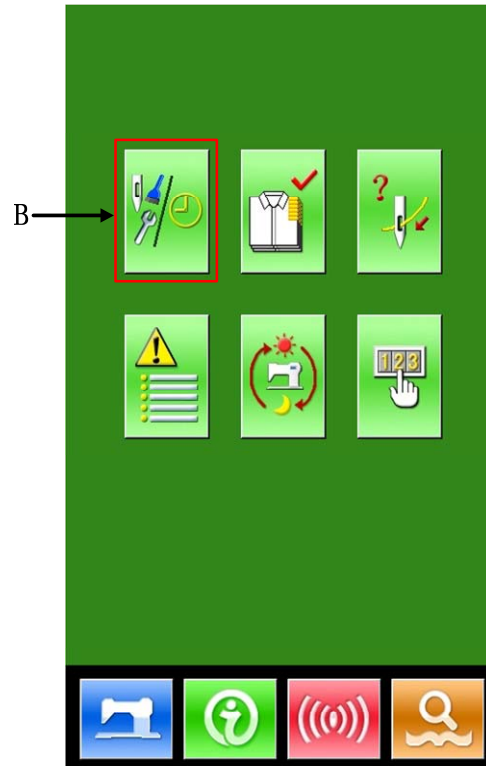

③ **Setting of Maintenance & Repair**

At Maintenance & Repair Information Interface, the information displayed is as same as that on the ordinary Maintenance & Repair Information Interface. Press the Item Button C (for changing the repair and maintenance time) to activate the relating input interface.

Exp. Pressing  is to set the cleaning time

Press  to return to the information interface directly

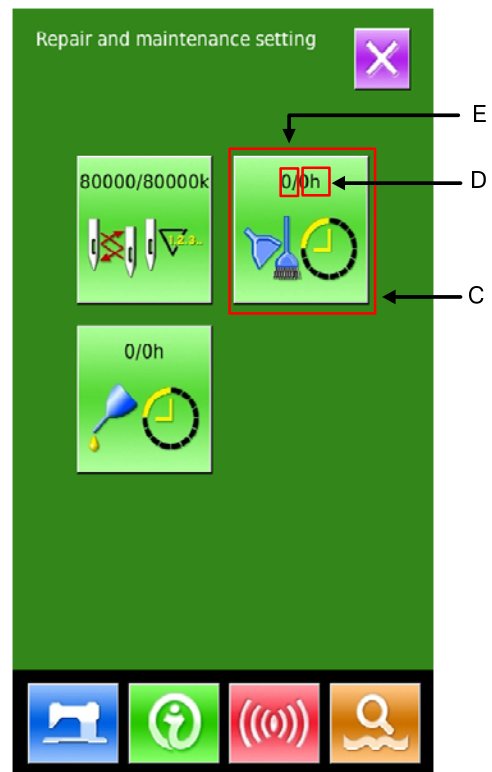

④ Set Maintenance & Repair Item

If the value of this item is set at 0, the function of maintenance & repair will be stopped.

The items for setting include:

- ◆ Needle Replacement Time
- ◆ Cleaning Time
- ◆ Oil Replacement Time

Press the figure to enter the corresponding interface:

A、 Input the value via keyboard

B、 Press  to confirm the input.

C、 Press  to return to the interface for repair & maintenance directly



6.3 How to Release Alarm

When it comes to the pointed time for maintenance or repair, the system will activate the prompt interface. If user wants to clear the maintenance and repair time, please press . Before the clearance of the maintenance and repair time, the information prompt interface will be displayed after each one sewing task.

The following are the prompt code for each item

- Needle Replacement : M-052
- Oil Replacement Time: M-053
- Cleaning Time: M-054

6.4 Production Control

In the interface of production control, the system will be able to display the amount of products from the beginning to now and the target producing amount, as long as the user fixes the time of start.

There are two ways to activate the production control interface:

- Via Information Interface
- Via Sewing Interface

6.4.1 Via Information Interface

① Display the Information Interface

At Interface for Inputting Sewing Data, press Information Key (A) to activate the Information Interface.

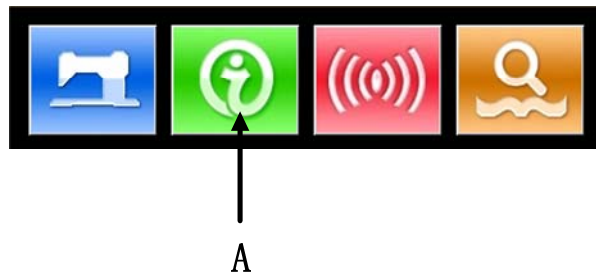

② Display the Production Control Interface

Please press Production Control Button (B) at the Information Interface so as to display the Production control interface (as shown at right picture) .

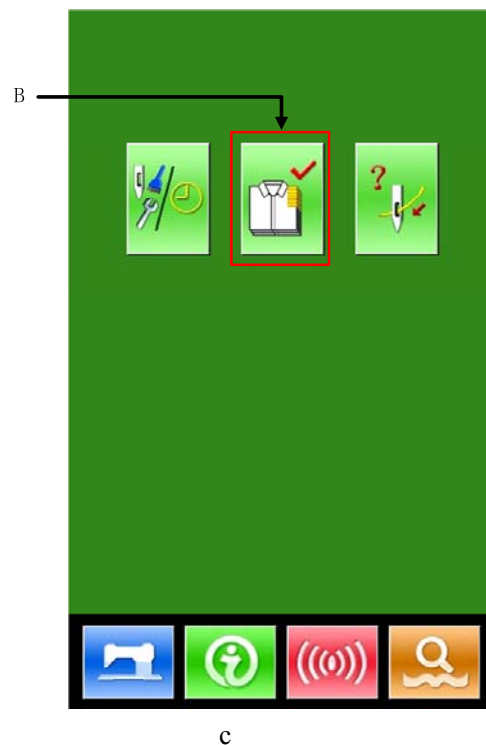

There are five items displayed on the production control interface

A: Existing Target Value

According to the pitch time, the target sewing amount up to now is displayed automatically.

B: Actual Result Value

Automatically display the amount of pieces sewn

C: Final Target Value

Set the final Target amount of production

D: Pitch Time of Target

Set the pitch time (Second) among each working process

E: Unit Interval of Actual

Set the actual time for finishing one process

6.4.2 Via Sewing Interface

① Display Sewing Interface

At Interface for Inputting Sewing Data,

user can press  to activate the Sewing Interface.

② Display Production Control Interface

At Sewing Interface, user can press Information Key (A) to activate the Production Control Interface.

The displayed content and the functions are same to the content in Chapter 6.4.1 at above.

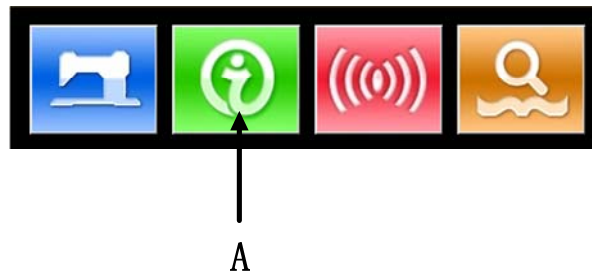

6.4.3 Setting on Production Control

① Display Production Control Interface

Press  to display the Production Control Interface

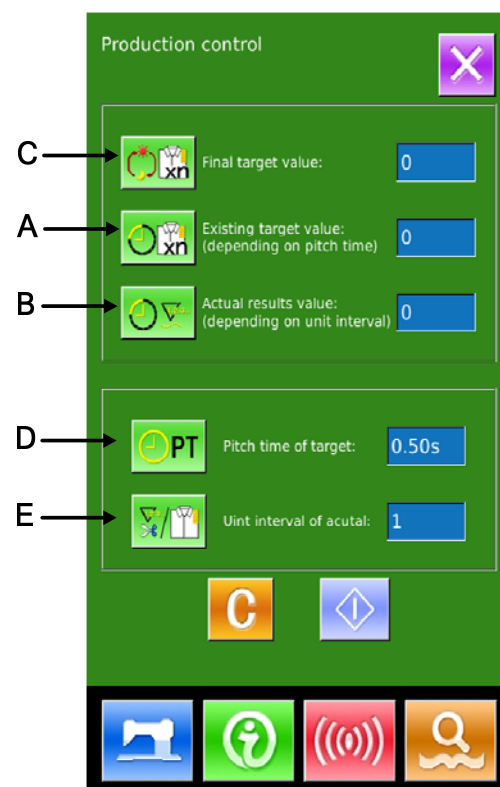



② Input Final Target Value

Firstly, please input the number of production target pieces to which the sewing is performed from now on. Press Final Target Amount Key



(C) to activate the Target Value Input Interface.

Please use the number keys or +/- keys to input the wished value. After the input, please press  to confirm. Press  to quit.

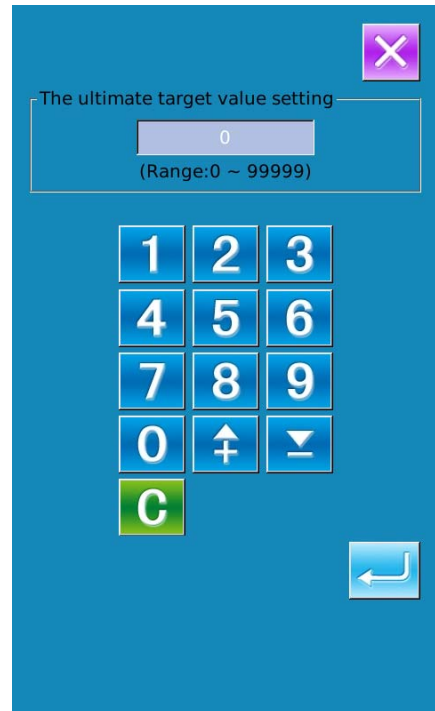



③ Input Pitch Time of Target

Then, input the pitch time needed for one process. By pressing the Pitch Time of Target Key



(D), user can activate the Pitch Time Input Interface.

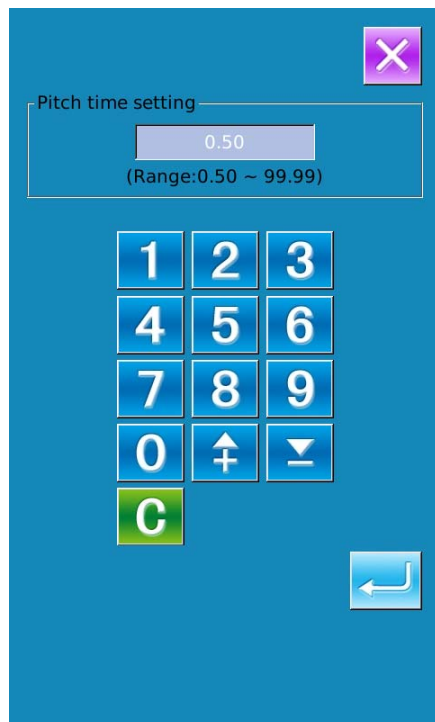

Please use the number keys or +/- keys to input the wished value. After the input, please press  to confirm. Press  to quit.



⑤ **Input Unit Interval of Actual**

Then, input the time for trimming at one process in average. By pressing Unit Interval of

Actual Key  (E) at previous page, the user can activate the Interface for Inputting Trimming Time

Please use the number keys or +/- keys to input the wished value. After the input, please press  to confirm. Press  to quit.

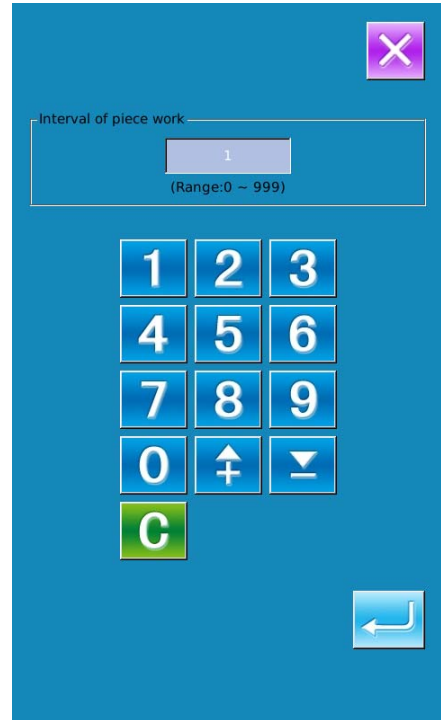

⑤ **Start to Count Amount of Production**

Press  (I) to start counting the number of production amount, the [Final Target Amount], [Target Amount at Present] and [Actual Amount] will turns to dark

Final Target Value: Can be used as the time reference



Existing Target Value: The target value adds 1 after each time pitch set [Pitch Time of Target]

Actual Result Value: After entry from the “6.4.2 Via Sewing Interface”, the system will start count the actual value by adding 1 at finishing each piece

By setting the Target Value and the Actual Result Value, user can find out the change of productivity.

⑥ **Stop Counting**

In the status of counting, you can see the

 displayed on the screen. Press  to

stop counting. After stop, the Counting Key 

will take the position of . If user wants to

continue counting, please press . Without

pressing , the value will be kept.

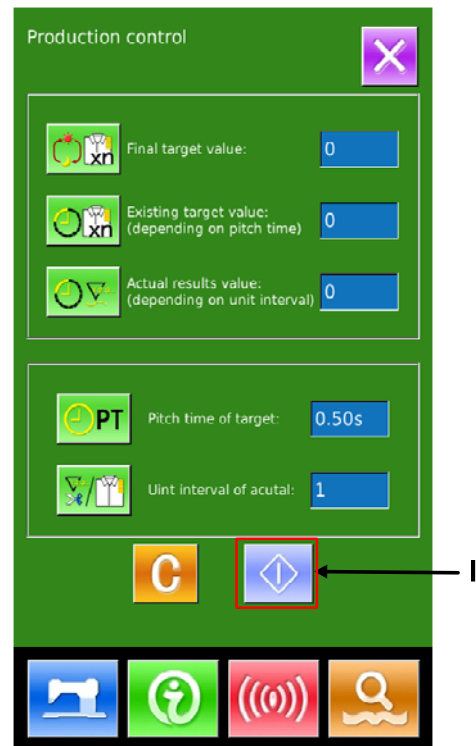

Press  to quit directly



⑦Clear the Data in Counter

For clearing the value of the counter, the user should stop the counter at first and then

press .

The values of  and  can be cleared both.

(Note: the clear key can only be displayed when the counter is stopped.)

After pressing , the Interface for Confirming Clearance is activated.

In the Interface for Confirming Clearance, user can press  to confirm the clearance.

Press  to quit.



6.5 Display Threading Figure

At Information Interface, user can press

Threading Button  (C) to activate the Threading Figure, which can be taken reference when user threads the machine.

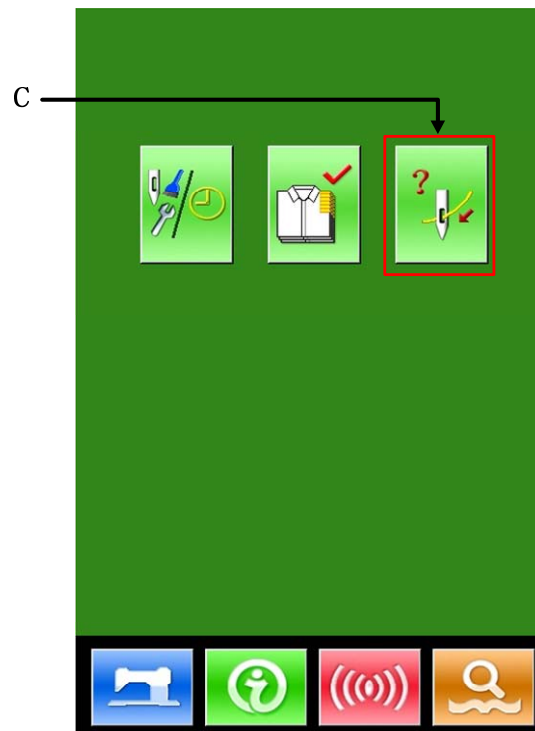

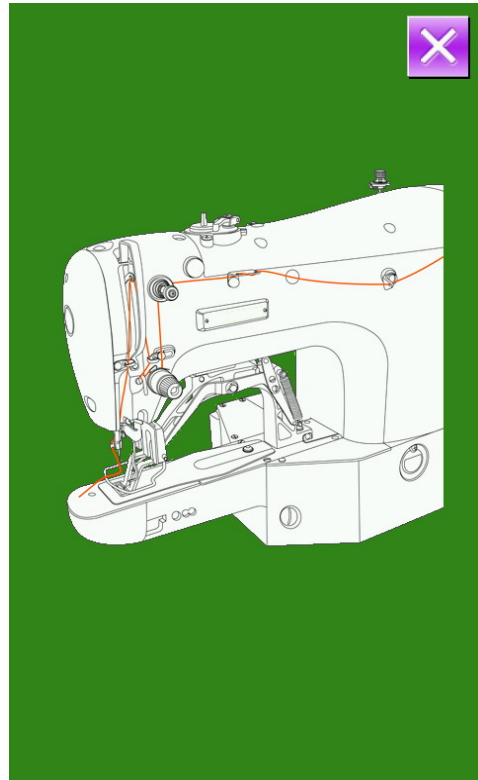

6.6 Alarm Record

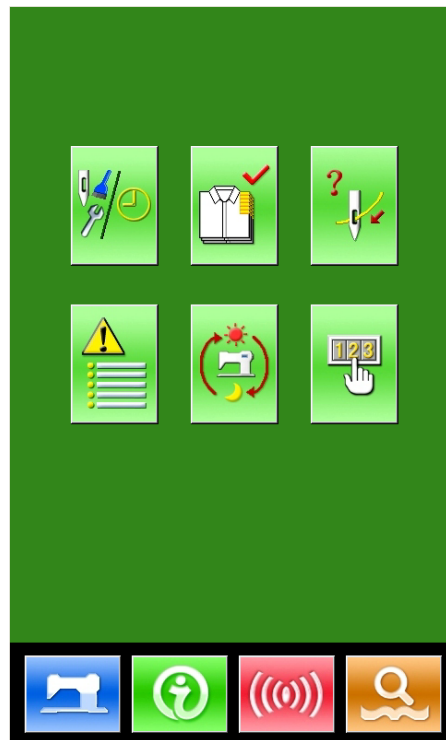

① At Maintenance Level, press  to inquire the alarm records.





② Press  to check the records

As in the picture, the warning information and the times of occurrence are displayed

Function of Keys:

A、 Press  or  to turn pages

B、 Press  to quit the inquiry

C、 Press  to clear the filed record

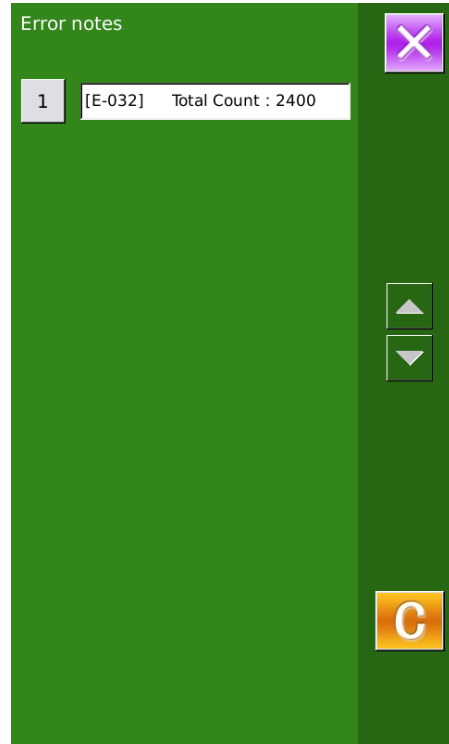

③ Press the number key at the left of the column to display the details of the warning records

Press  to quit

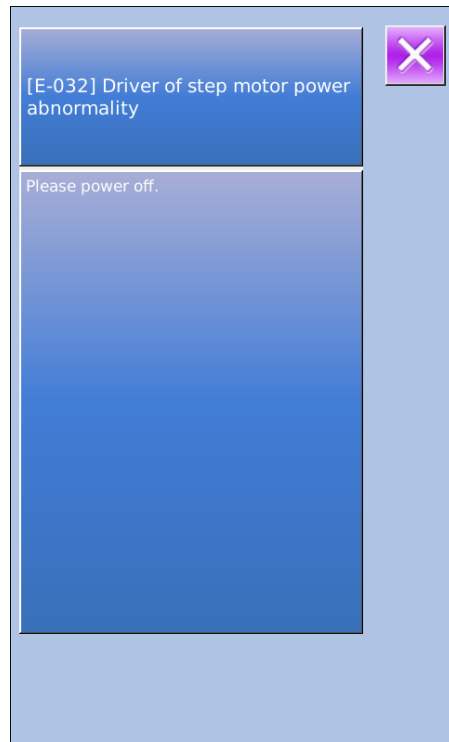

6.7 Running Record

① In the interface of maintenance level,

press  to check the running information of the machine.

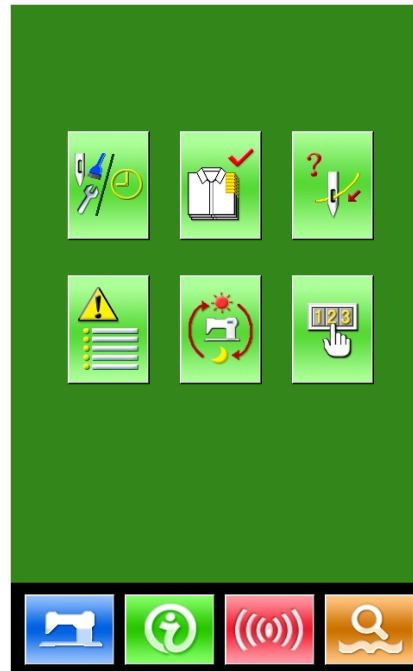

② **The Running Records contain:**

- a) : Accumulated running time (Hour)
- b) : Accumulated times for thread trimming
- c) : Accumulated time of power-on (Hour)
- d) : Accumulated number of stitch (1000stitch)

A、 Press  to quit

B、 Press Clear to clear the record

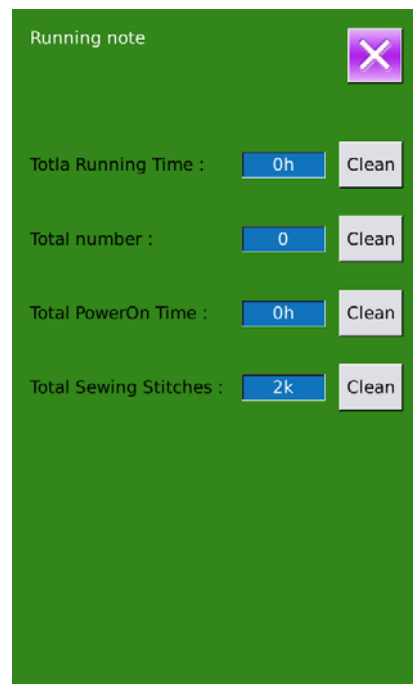

6.8 Setting of Periodical Password

- 1) In maintenance level, Press  to set periodical password

In this interface, the system will ask user to input the User ID. Input the right manufacturer ID to enter the password management mode, where user can set and manage the periodical passwords.



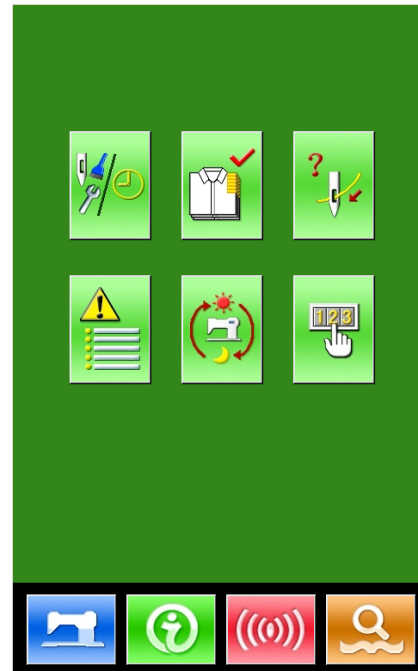

- ◆ At most ten periodical passwords with different activation dates can be set
- ◆ The system will display the information of passwords set by manufacturer.

- 2) Press  To input User ID



Input User ID

| | | | | | |
|---|---|---|---|---|---|
| 1 | 2 | 3 | 4 | 5 | 6 |
| 7 | 8 | 9 | 0 | A | B |
| C | D | E | F | G | H |
| I | J | K | L | M | N |
| O | P | Q | R | S | T |
| U | V | W | X | Y | Z |

3) Input the Correct Factory ID to enter the password setting interface

Procedure for setting the periodical password:

- A、 Continue inputting other periodical passwords



4) Input Board Number

Press **【Board Number】** to enter the board number input interface. Input the board number

and press  to finish the input

※ The board is a four-figure number, from 0~9999

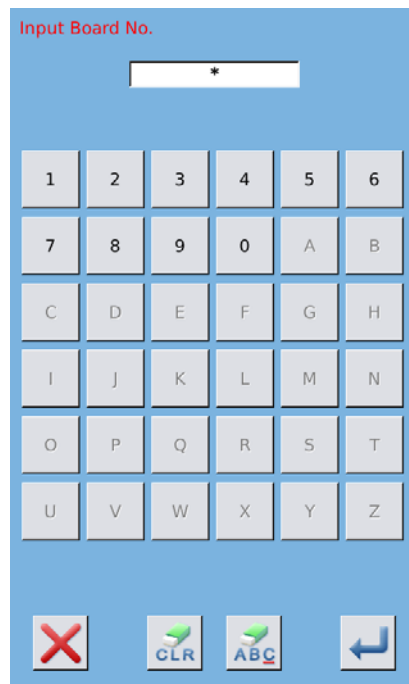

5) Input System Clock

Press【Clock】 to enter the interface for setting the system clock. And set the time.



6) Input the super password

Press the 【Super Password】 to enter the interface for setting super password

- ※ **At most, nine super passwords can be input**
- ※ **At the password confirmation, make sure the two input passwords are same**

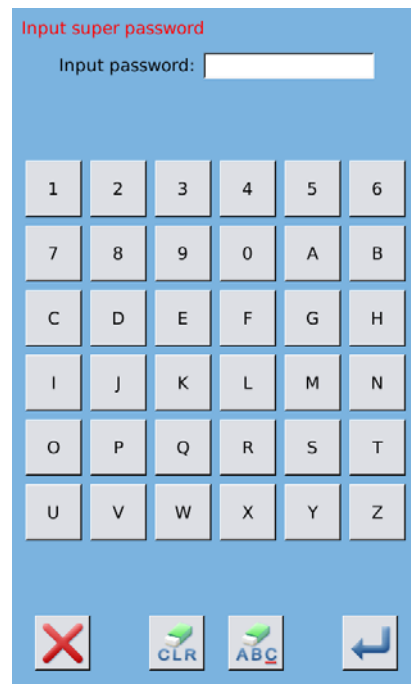

7) Input periodical password

Press **【 Password-1 】** to enter the first password date, where user can input the first date for activation. After selecting the proper date, user can press  for confirmation. Then enter the password setting interface to input the password.

- ※ **The date should not be earlier than the system date**
- ※ **At the password confirmation, make sure the two input passwords are same**

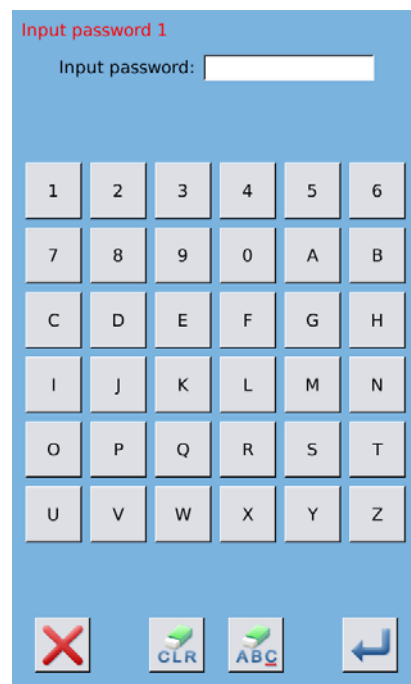

8) Input other periodical password

The setting of other periodical password is same to that in step ⑦. Please take the reference to that

※ **The next activation date shall be later than the previous date.**



9) Save Password

A、 After inputting the password, please press

 to save it.

B、 After the password is saved, the system will display 【Save the password successfully】 .

Press  to finish the operation and return to the main interface of information.

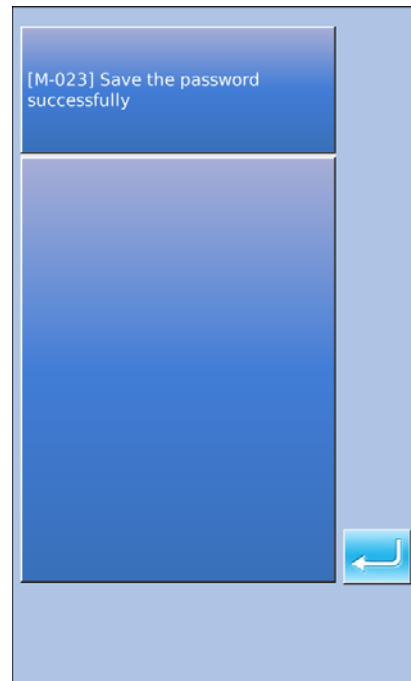

10) Clear Password at Activation

If the system has password and that password is still effective, it will be activated at the activation day.

If user wants to use the machine he should input the right password.

A、The effective passwords include current password and super password

B、If the current password is input, the current password will be deleted. After user clears the current password, if it is the last password in machine, no more activation of password will happen in future.

C、If the super password is input, all the periodical passwords will be deleted.



11) Clear Password at Activation

If the system has password and that password is still effective, it will be activated at the activation day.

If user wants to use the machine he should input the right password.

A、The effective passwords include current password and super password

B、If the current password is input, the current password will be deleted. After user clears the current password, if it is the last password in machine, no more activation of password will happen in future.

C、If the super password is input, all the periodical passwords will be deleted.

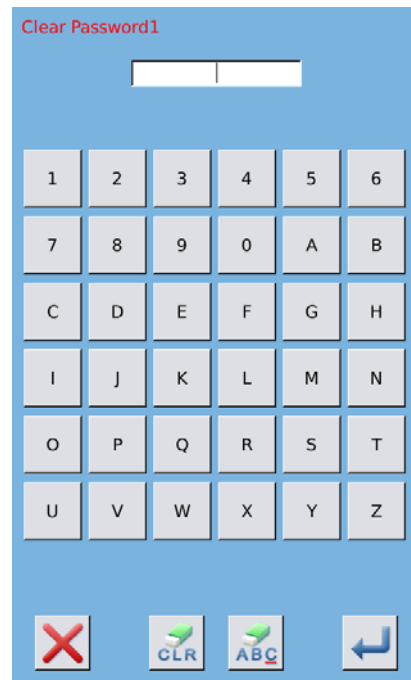

7 Communication Functions

At Communication, user can perform the following functions:

- Download the sewing data made at other sewing machines or produced by the pattern-designing software to the sewing machine;
- Load sewing data to U disk or computer
- Load parameters from U disk
- Input the parameters within the operation panel to U disk
- Update the software within the operation panel

7.1 About the Available Data

The available data is shown at below, as well as the data type:

| Data Type | Standard Type |
|------------------|---|
| VDT | [0-9][0-9][1-9].vdt |
| DXF | [0-9][0-9][1-9].dxf |
| DST/DSB | [0-9][0-9][1-9].dst/ [0-9][0-9][1-9].dsb |
| B/BA | [0-9][0-9][1-9].(1-599)/ [0-9][0-9][1-9].(600-999) |
| PAT | [0-9][0-9][1-9].pat |

When saving data to the U disk, user needs save it to the DH_PAT folder. Otherwise, the file is unable to be read.

7.2 Operations

① Display the Communication Interface

In the data input interface, press  to display the communication interface.

② Select the relating operations

The following three kinds of functions can be selected in this interface:

- Pattern Transfer
- Parameter Transfer
- Software Update

Click the corresponding figure to perform the operations.

③ Press to quit the Communication

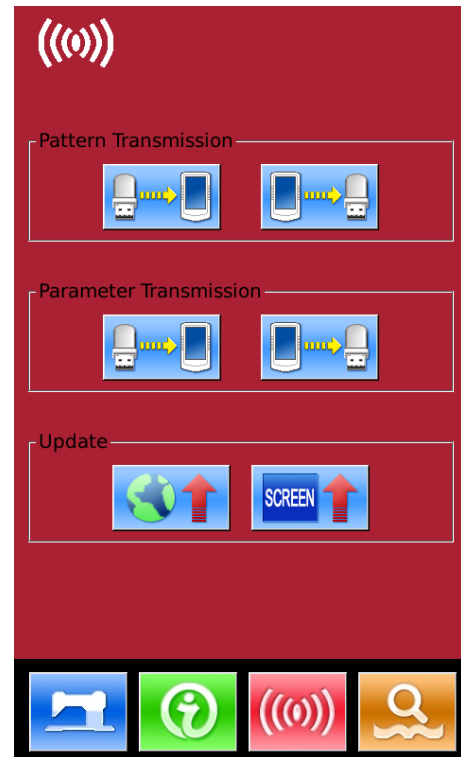

7.3 Pattern Transfer

① Display the Communication Interface

In communication interface, press:

A: Input patterns from U Disk to Operation Panel

B: Output patterns from Operation Panel to U Disk

Path of U Disk: DH_PAT

- ※ **When inputting patterns from U disk, user has to save the pattern into the DH_PAT in the U disk.**
- ※ **When outputting patterns from operation panel, user has to save the pattern into the DH_PAT in the U disk.**
- ※ **Naming Method of Patterns within U Disk**

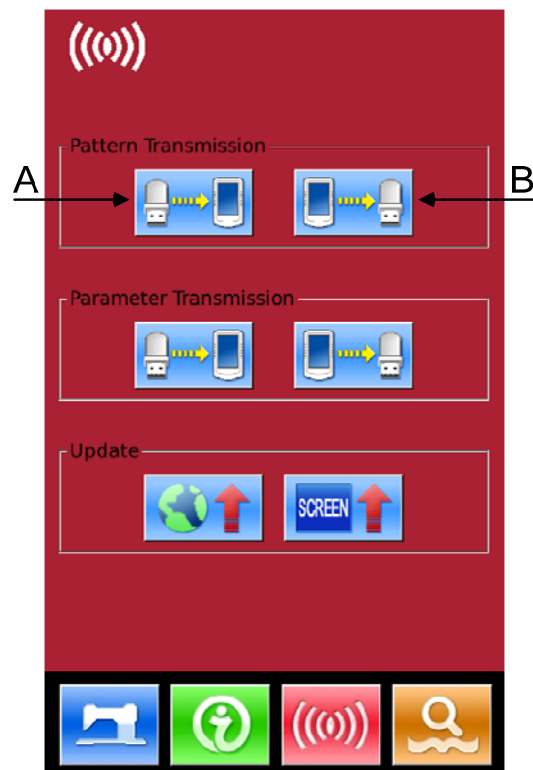

When inputting patterns from U disk, user needs follow the naming rule at below::

File Name: 3 figures, 001~999

Suffix: vdt (no matter at CAP or not)

Example:

Right Names: 100.vdt、102.VDT



Other naming methods are wrong, which can not be recognized by machine

② **Press button A to enter the interface for inputting patterns from U Disk**

Note: If the pattern in U disk has the same name to the pattern within the panel, the pattern number will be displayed in red. The pattern with red code can only be inputted with button F, as shown in figure 1

A、Use【Up Arrow】，【Down Arrow】to turn the page

B、Use these three methods to select patterns

- Press  to select all the patterns
- Press  to select in contrary way
- Input Pattern Number

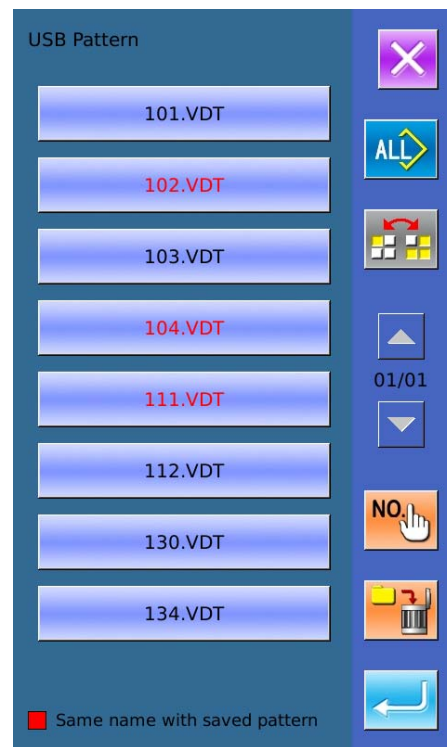





Figure 1

C、 Press  to finish pattern input. At this moment, the patterns inputted and the patterns selected share the identical pattern number, as shown in figure 2

D、 Press  to delete the selected pattern

E、 Press  to quit Communication Interface

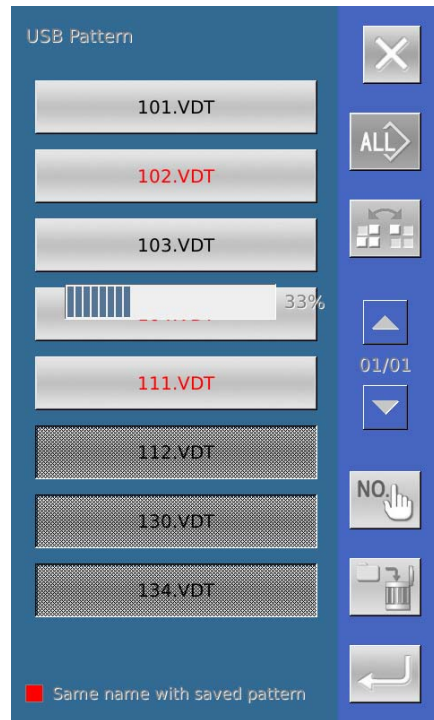



Figure 2

F、 Select a pattern and then press  to display the interface shown as figure 3.

Input the pattern number for saving;

G、 If user selects several patterns, he will be unable to perform the above operation.

Press  to quit to the previous r interface

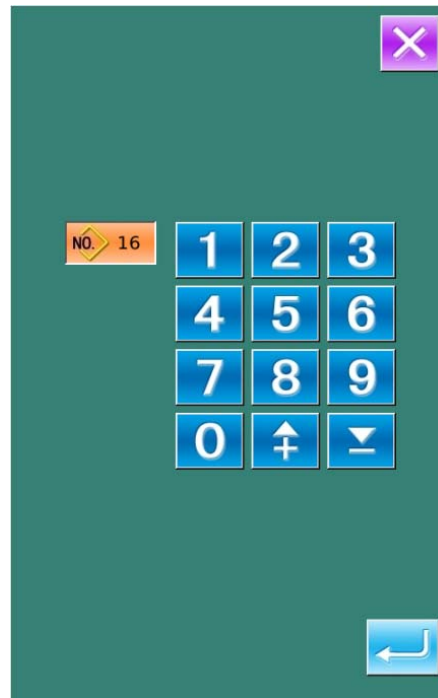

Figure 3

Attention: If the selected pattern number exists in operation panel, the screen as the figure 4 will be displayed. If the data is in other format, the panel will automatically turn it to the vdt format and save it into memory.

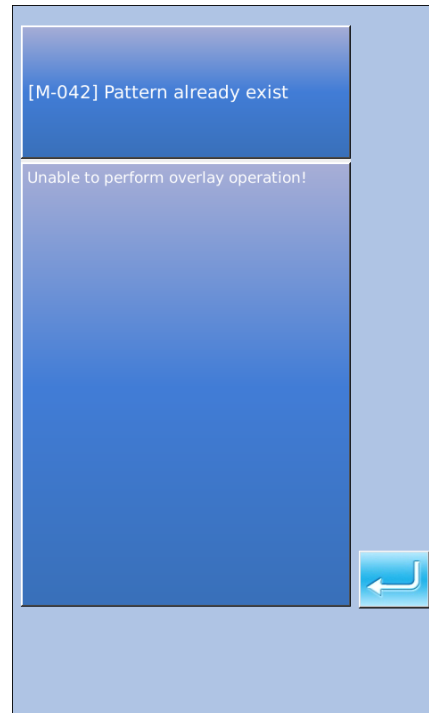





Figure 4

③ Press Button B to enter the interface for outputting patterns from panel to U Disk.

A、 Use 【Up Arrow】 , 【Down Arrow】 to turn the page

B、 Use these three methods to select patterns

- Press  to select all the patterns
- Press  to select in contrary way
- Input Pattern Number

C、 Press  to delete the selected pattern

D、 Press  to finish pattern output

E、 Press  to quit Communication Interface

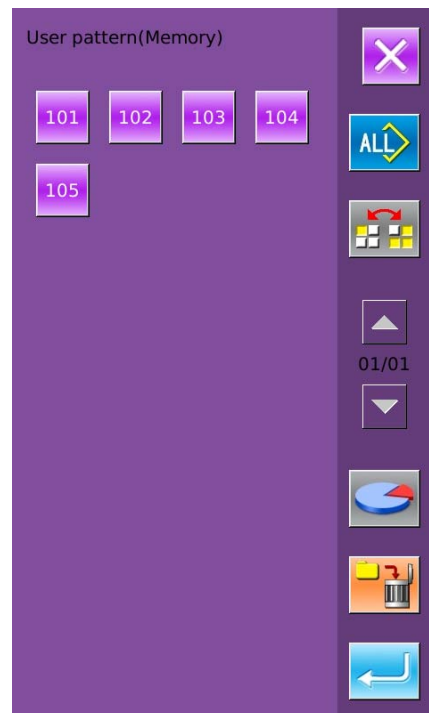

F、 In this interface, press  to display the free room of the memory and the number of pattern.

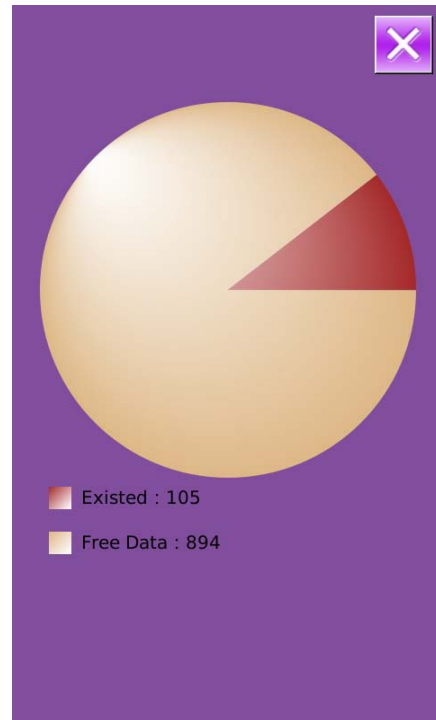

7.4 Parameter Transfer

① Display the Communication Interface

In communication interface, press:

A: Input parameters from U Disk to Operation Panel

B: Output parameters from Operation Panel to U Disk

- ※ When inputting patterns from U disk, user has to save the parameters into the DH_PARA in the U disk with name ukParam.
- ※ When outputting patterns from operation panel, user has to save the parameters into the DH_PARA in the U disk with name ukParam.
- ※ The parameter file is the binary file, which is operated on the control panel. User can not change that file manually on PC, or the file may be damaged

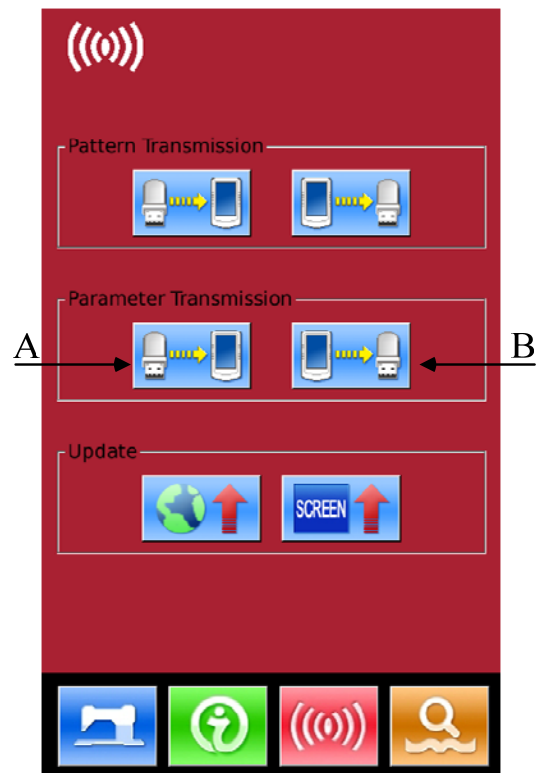

② **Press Button A to Input Parameters from U Disk to Operation Panel**

A、 Press  to input the parameters and quit

B、 Press  to quit directly.

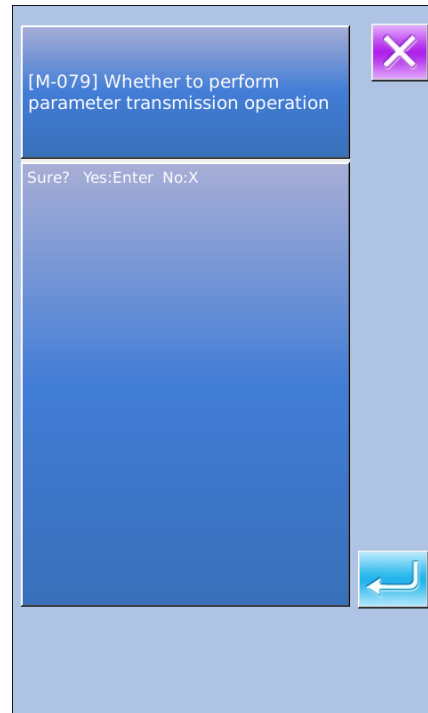

③ **Press Button B to Output Parameters to Operation Panel**

A、 Press  to output parameters from operation panel to U disk and quit

B、 Press  to quit directly

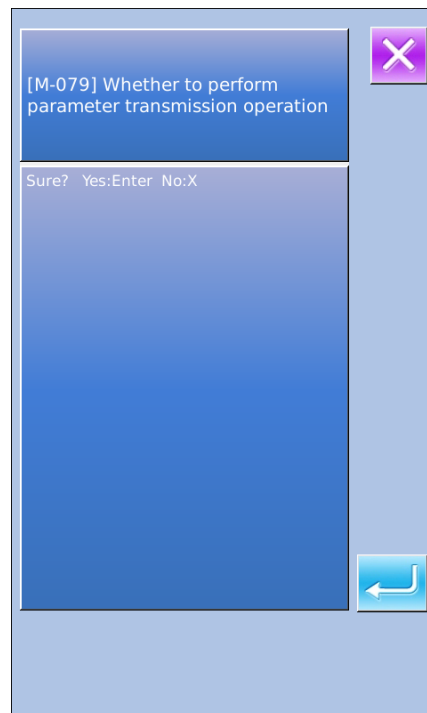

7.5 Software Update

1) Display the Interface

In Communication interface, press A to enter Software Update Interface

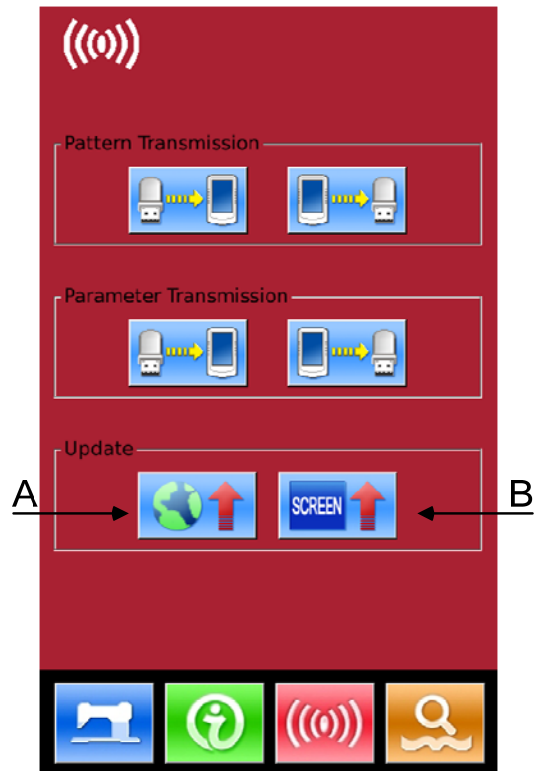

2) Update Selection

The software update contains:

- ◆ Operation Panel Software
- ◆ Icon
- ◆ Font
- ◆ Power-on Screen

Press and to turn the page

A、 Press to finish the selected update and quit

B、 press to quit directly

C、 User can select several items for update at same time. The system will perform the update according to the order

D、 After the update, please restart the machine.

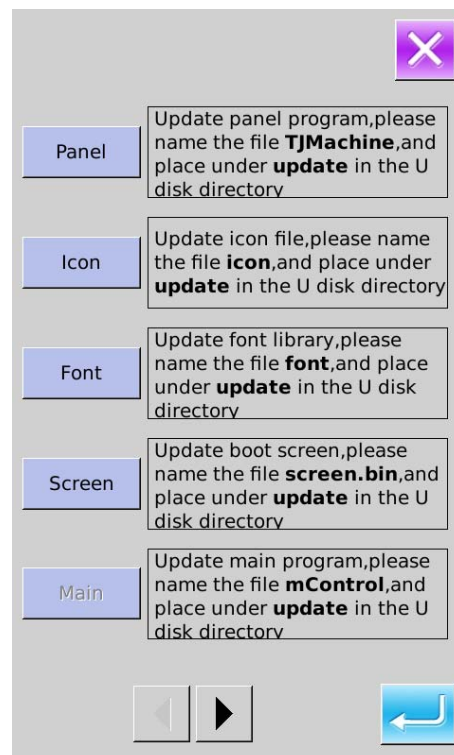

3) Press B to enter the interface for updating the power-on screen

Put the bin file (generated from the power-on screen) into the “Update” catalogue in U disk. Select the bin file and

then press  to finish the update.

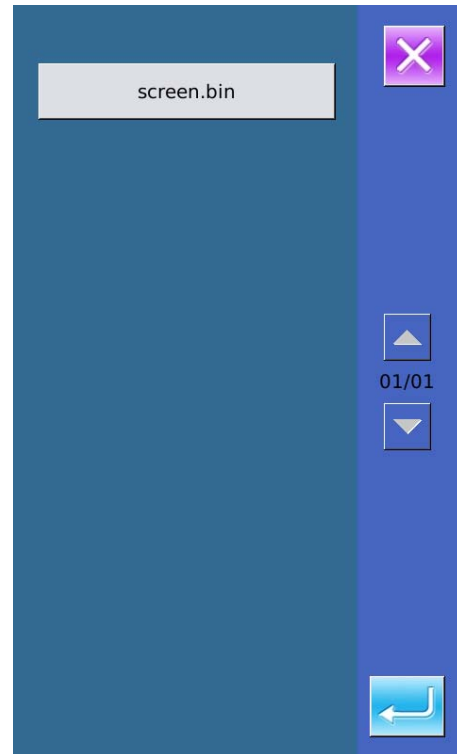

8 Mode & Parameter Setting

Press  to shift from the Data Input Interface to the Mode Interface (as shown in right figure), where user can perform some detailed settings and editions.

Hold  for 3 seconds to have access to Mode Setting Level 2 Interface; hold for 6 seconds to have access to Mode Setting Level 3 Interface.

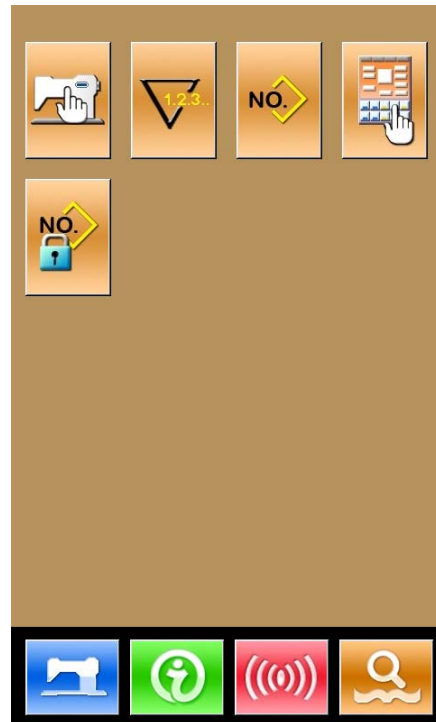

Mode Setting Level 2 Interface

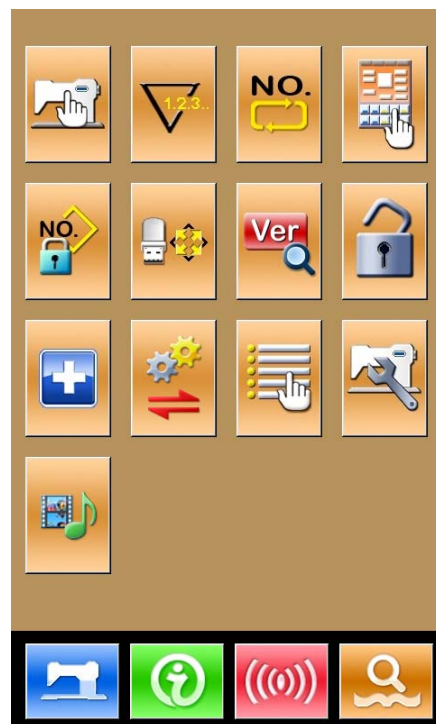

Mode Setting Level 3 Interface

8.1 List of Function Keys

| No. | Figure | Functions | Content |
|-----|---|----------------------------|--|
| 1 |  | Level 1 Parameters Setting | Set the Level 1 (U) parameters |
| 2 |  | Counter Setting | Set the type of counter, counting value and default value |
| 3 |  | Sewing Type Setting | Shift between normal pattern sewing and combination pattern sewing |
| 4 |  | Pattern Lock | Enter the interface for locking pattern |
| 5 |  | Pattern Edition | Have access to pattern edition status |
| 6 |  | U Disk Initialization | Initialize the U disk. |
| 7 |  | Software Version Inquiry | Inquire the versions of the current panel, main controller and motor |
| 8 |  | Keyboard Lock | Lock some functions that can be set. |
| 9 |  | Test Mode | Set the mechanical devices and LCD |
| 10 |  | Parameter Back-up | Backup or recover the current parameters |
| 11 |  | Activate Parameter Edition | Activate or deactivate the edition of parameters |
| 12 |  | Level 2 Parameters Setting | Set the Level 2 (K) parameters |
| 13 |  | Play Video | Play the video |

8.2 Level 1 Parameters Setting

① Set Parameter

Select  to enter the interface of Level 1 parameter setting (shown as the figure at right).

Press  to quit the setting interface

When some parameters are changed, the system will display the “Modified” in the parameter setting interface.

Select the parameter for changing; Then the system will enter the setting status. The parameters are separated as “Data Input Type” and “Selection Type”. Please refer to the example at below:

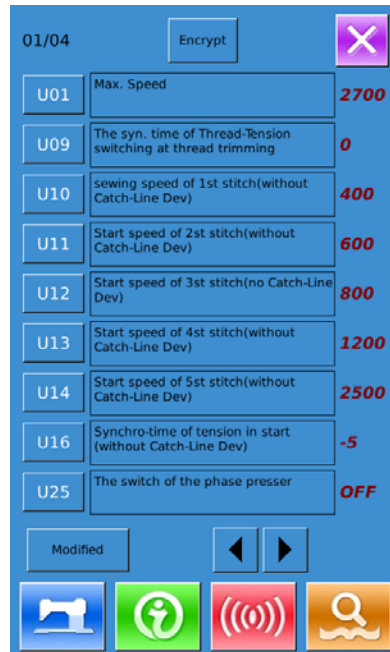

Select U01 and enter the interface below



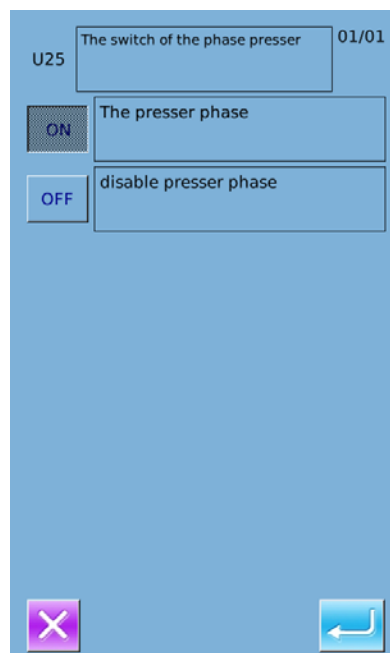

Select U25 and enter the interface below:



② **Parameter Encryption**

A、 Press “Encryption” to enter the password input interface.

Press  to clear all the content

Press  to erase one figure at each pressing

B、 Input the right password to enter the interface for parameter encryption

Select the parameter for encryption

Press **【Select All】** to attach password to all the parameters

Press **【Reverse】** to select parameter for encryption in reverse way

Press **【Change】** to change the password, the default is the manufacturer ID

Press  to quit the encrypting function

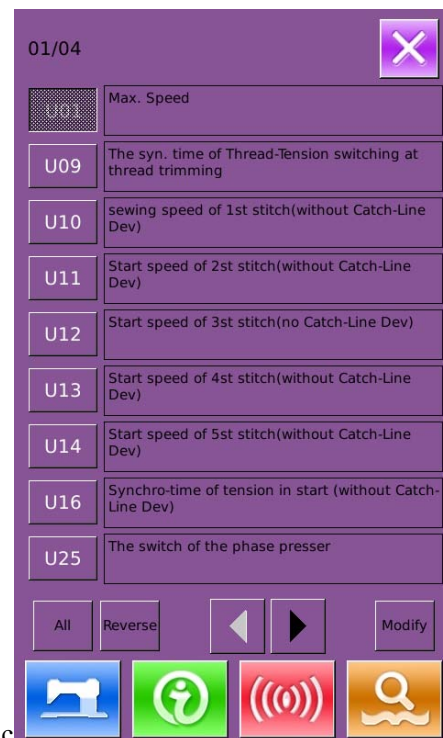
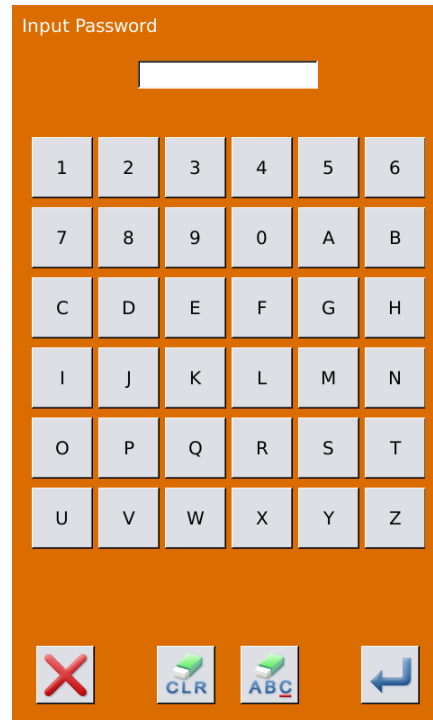

③ Check the changed parameter

A、 When parameter is changed, the system will display “Modified” key at parameter setting interface.

B、 In the parameter setting interface, press **【 Modified 】** to check the changed parameters.

At first, the system will ask user to input the password. For the operation at password input interface, please refer to the “A” at ②. After inputting the right password, user can enter the interface for inquiring changed parameters.

C、 Under the interface of changed parameter inquiry, user can find the list containing all the changed parameters with their current value and default value.

In that interface:

- Press **【 All Rest 】** will restore all the changed parameters to their default values
- Click Parameter Name, like **【 Presser Type 】** and then press **【 Select Rest. 】** to restore this parameter to the default value. User can select many parameters at here.
- Press Parameter Number, like **【 U14 】** to enter the parameter setting interface, where user can reset the parameter value.
- When the pages are more than one, user can use arrow key to turn the page
- Press  to quit the interface.

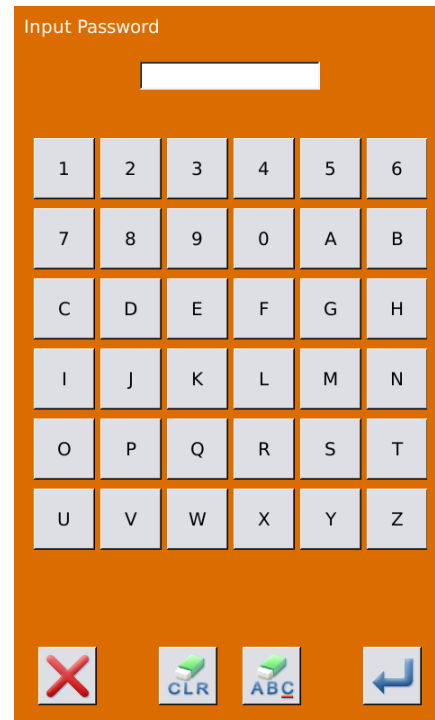

④ List of Level 1 Parameters

| No. | Parameter | Range | Unit | Default value |
|-----|--|--|--------|---------------|
| U01 | Max Sewing Speed | 400~3000 | 100rpm | 2700rpm |
| U09 | Thread Tension Changeover Timing at thread-trimming | -6~4 | 1 | 0 |
| U10 | Start Speed of 1 st Stitch | 400~1500rpm | 100rpm | 400rpm |
| U11 | Start Speed of 2 nd Stitch | 400~3000rpm | 100rpm | 900rpm |
| U12 | Start Speed of 3 rd Stitch | 400~3000rpm | 100rpm | 2700rpm |
| U13 | Start Speed of 4 th Stitch | 400~3000rpm | 100rpm | 2700rpm |
| U14 | Start Speed of 5 th Stitch | 400~3000rpm | 100rpm | 2700rpm |
| U16 | Thread Tension Changeover Phase at Sewing Start | -5~2 | 1 | -5 |
| U25 | Presser Height Division Switch ON: Permit Presser Height Division OFF: Forbid Presser Height Division | 0: Permit Presser Height Division 1: Forbid Presser Height Division | 1 | 1 |
| U26 | Adjustment of Divided Presser Height at 2 Levels' Stroke | 50~90 | 1 | 70 |
| U27 | Counting Unit of the Sewing Counter | 1~30 | 1 | 1 |
| U31 | Stop Sewing Machine with Button on Panel OFF: Invalidity PANEL: Pause Key at Panel EXT: External Switch | 0: Invalidity 1: Pause Key at Panel 2: External Switch | 1 | 1 |
| U32 | Settings on Buzzer Sound OFF: Silence PAN: Operating Sound ALL: Operating Sound + Alarm | 0: Silence 1: Operating Sound 2: Operating Sound + Alarm | | 2 |
| U36 | Select Time for Feeding Actions | -8~16 | 1 | 12 |
| U37 | Presser Status at Sewing End 0: Return and then lift presser 1: Lift presser and then return | 0: Return and then lift presser 1: Lift presser and then return | 1 | 1 |
| U38 | Presser Goes Up at Sewing End ON: Presser Up Permitted. OFF: Presser Up Forbidden | 0: Presser Up Permitted. 1: Presser Up Forbidden. | 1 | 0 |

| No. | Parameter | Range | Unit | Default value |
|------|---|--|--------|---------------|
| U39 | Search Origin at Sewing End OFF: Not Search ON: Search | 0: Not Search 1: Search | 1 | 0 |
| U40 | Origin-Searching at Sewing Combination Patterns OFF: Not Search Origin PAT: Search Origin at Finishing Each Pattern CLC: Search Origin at Finishing Each Cycle | 0: Not Search Origin 1: Search Origin at Finishing Each Pattern 2: Search Origin at Finishing Each Cycle | 1 | 0 |
| U41 | Search Origin at Shifting P Pattern OFF: Invalid ON: Valid | 0: Invalid 1: Valid | | 0 |
| U42 | Needle Rod Stop Position UP: Upper Position DEAD: Highest Point | 0: Upper Position 1: Highest Point | 1 | 0 |
| U46 | Permit Trimming the Thread ON: Permit OFF: Forbid | 0: Permit 1: Forbid | 1 | 0 |
| U49 | Winding Speed Setting | 800~2000 | 100rpm | 1600rpm |
| U64 | Select Unit for Size Change %: Input Percentage SIZ: Input Actual Size | 0: Input Percentage 1: Input Actual Size | | 0 |
| U88 | Scale Mode OFF: Forbidden PIT: Change at Stitch Pitch STI: Change at Stitch Number | 0: Forbidden 1: Changes at Stitch Pitch 2: Changes at Stitch Number | | 1 |
| U97 | Thread-trimming Method after Pause AUT: Automatic MAN: Manual | 0: Automatic 1: Manual | 1 | 0 |
| U135 | Return to Start Point or Origin at Sewing End 0: Start Point 1: Origin | 0: Start Point 1: Origin | 1 | 0 |
| U190 | Back Light Auto Off OFF: Not Auto Off ON: Auto Off | OFF: Not Auto Off ON: Auto Off | | 0 |

| No. | Parameter | Range | Unit | Default value |
|------|---|--|------|---------------|
| U191 | Back Light Off Wait Time | 1~9 | 1m | 3m |
| U192 | Back Light Adjustment | 20~100 | | 100 |
| U193 | Modify the Counter Value OFF: Permit ON: Forbid | 0: Permit 1: Forbid | | 0 |
| U194 | Operation at Reaching set value of Counter OFF: Stop Sewing ON: Continue Sewing | OFF: Stop Sewing ON: Continue Sewing | | 0 |
| U195 | Voice Column | 30~63 | | 50 |
| U200 | Language 0: Chinese 1: English | 0: Chinese 1: English | | 0 |
| U201 | Set Language at Power-on OFF: No ON: Yes | OFF: No ON: Yes | | 0 |
| U212 | Presser Down Order at Separating Valves 0: Same Time 1: Left then Right 2: Right then Left | 0: Same Time 1: Left then Right 2: Right then Left | | 0 |
| U213 | Presser Up Order at Separating Valves 0: Same Time 1: Left then Right 2: Right then left | 0: Same Time 1: Left then Right 2: Right then Left | | 0 |
| U214 | Reverse Presser OFF: Forbid ON: Enable | OFF: Forbid ON: Enable | | 1 |

8.3 Level 2 Parameters Setting

① Parameter Setting

At Mode Setting Level 3 Interface, press 

to have access to Level 2 Parameter Setting Interface (as shown in right picture). For the operation methods, please refer to descriptions at [8.2 Level 1 Parameters Setting](#).

When some parameters are changed, the system will display the “Modified” in the parameter setting interface.

Press  to quit the setting interface

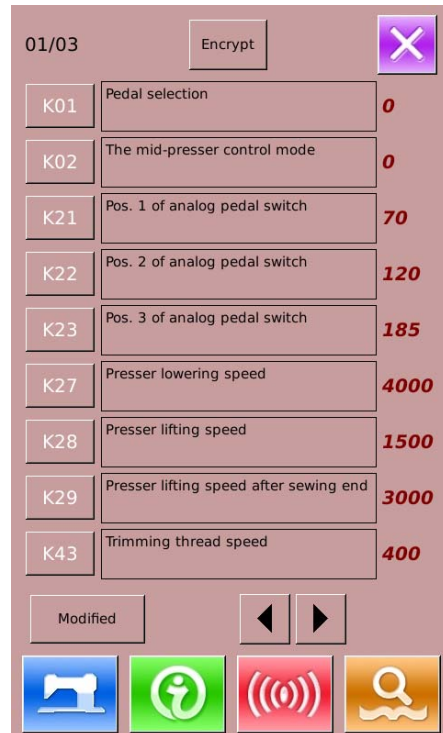

② Parameter Encryption

For the operations, please refer to the description within “[8.2 Level 1 Parameters Setting](#)”

Press  to quit parameter encryption interface

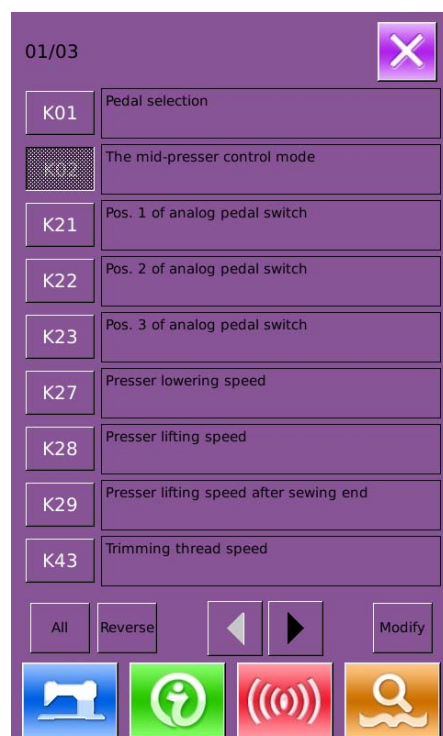

③ Check the changed parameters

When parameter is changed, the system will display “Modified” key at parameter setting interface

In the parameter setting interface, press 【 Modified 】 to check the changed parameters. User can also reset the parameters here.

For the specific operation, please refer to “7.2 Level 1 Parameter Setting”

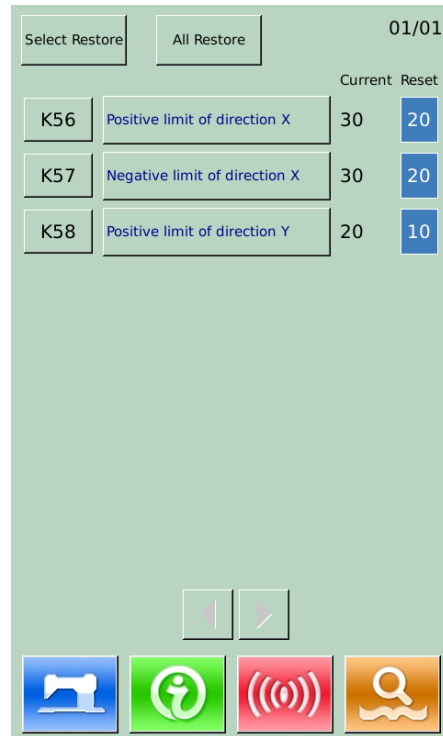

④ 二级参数表

| No. | Parameters | Range | Unit | Default |
|-----|--|---|-------|---------|
| K01 | Pedal Selection 0: Simulate 2: Double Pedals 3: Double Pedals, only the operation pedal can control machine | 0: Simulate 2: Double Pedals 3: Double Pedals, only the operation pedal can control machine | 1 | 0 |
| K02 | Presser Control 0: No Presser Control 2: Presser Controlled by Solenoid 3: Presser Controlled by Mechanism | 0: No Presser Control 2: Presser Controlled by Solenoid 3: Presser Controlled by Mechanism | | 0 |
| K21 | Simulated Pedal Position 1 | 50~200 | 1 | 70 |
| K22 | Simulated Pedal Position 2 | 50~200 | 1 | 120 |
| K23 | Simulated Pedal Position 3 | 50~200 | 1 | 185 |
| K27 | Speed for Lowering Presser | 100~4000pps | 10pps | 4000pps |
| K28 | Speed for lifting Presser | 100~4000pps | 10pps | 1500pps |

| No. | Parameters | Range | Unit | Default |
|------|---|--|--------|---------|
| K29 | Speed for Lifting Presser at Sewing End | 100~4000pps | 10pps | 3000pps |
| K43 | Trimming Speed | 300~700rpm | 100rpm | 400rpm |
| K44 | Empty Feeding Control At Thread-trimming OFF: Ineffective ON: Effective | OFF: Ineffective ON: Effective | 1 | 1 |
| K45 | Needle Guider Diagram at Controlling Empty Feeding | 1.6~4.0mm | 0.2mm | 1.6mm |
| K56 | Move Range +X Direction | 0~50mm | 1mm | 20mm |
| K57 | Move Range -X Direction | 0~50mm | 1mm | 20mm |
| K58 | Move Range + Y Direction | 0~30mm | 1mm | 10mm |
| K59 | Move Range -Y Direction | 0~30mm | 1mm | 20mm |
| K64 | Thread-stirring Method 0: By Solenoid 1: By Motor | 0: By Solenoid 1: By Motor | 1 | 1 |
| K74 | Selection of Solenoid/ Air-driven Presser AIR: Air-driven Presser MOTO: Motor Presser | AIR: Air-driven Presser MOTO: Motor Presser | 1 | 1 |
| K95 | Trimming Angle | -10~10 | 1 | 0 |
| K112 | Stop Position Compensation | -10~10 | 1 | 0 |
| K122 | OC | -128~128 | 2 | 0 |
| K123 | OD | -128~128 | 2 | 0 |

| No. | Parameters | Range | Unit | Default |
|------|--|---|------|---------|
| K124 | BD | -512~512 | 4 | 0 |
| K135 | Solenoid Junction Delay | -10~30 | 1 | 0 |
| K137 | Solenoid Thread-catching Angle Deviation | -150~150 | 1 | 0 |
| K138 | Solenoid Close Delay | -1~1 | 1 | 0 |
| K140 | Thread Tension Control Method 0: Electronic Method 1: Mechanical Method | 0: Electronic Method 1: Mechanical Method | 1 | 1 |
| K141 | Adjustment of Close Force at Branch Tension Solenoid | -20~20 | 1 | 0 |
| K142 | Adjustment of Holding Force at Branch Tension Solenoid | -40~40 | 1 | 0 |
| K150 | Head Safety Switch ON: Normal OFF: Forbid | ON: Normal OFF: Forbid | | 0 |
| K200 | Restore Default Settings | | | |
| K241 | Type Setting Note: At changing the machine type, the system will re-add the basic patterns and delete the saved normal patterns Note 2 :Unable to see at JK 1906 | 0: Bar-tacking Machine 5: 1906 Machine 7: Button Sewing Machine | | 0 |

8.4 Counter Setting



Press  to have access to the Counter Setting Interface (as shown in right picture).

Procedure:

① Counter Selection

Select Sewing Counter or No.of Pcs Counter

② Set the Current Value and the Set Value of Counter

At the set type, press the “Current” or “Setting” to perform the relating operation.

③ Select Up Counter or Down Counter

At the selected type, please press “Up” and “Down” to perform the relating operations



Press  to quit counter setting interface



Press  to finish setting and quit.

Sewing UP Counter :

Every time the sewing of one shape is performed, the existing value is counted up 1. When the existing value is equal to the set value, the interface of counter exceed warning will be displayed. Press  to restore the existing value to 0

Sewing DOWN Counter :

Every time the sewing of one shape is performed, the existing value is counted down 1. When the existing value is reached to "0", the interface of counter exceed warning will be displayed. Press  to restore the existing value to the set value.

No of piece UP counter :

Every time a cyclic sewing or a continuous sewing is performed, the existing value is counted up 1. When the existing value is equal to the set value, the interface of counter exceed warning will be displayed.

Press  to restore the existing value to 0

No of piece DOWN counter:

Every time a cyclic sewing or a continuous sewing is performed, the existing value is counted down 1. When the existing value is reached to "0", the interface of counter exceed warning will be displayed.

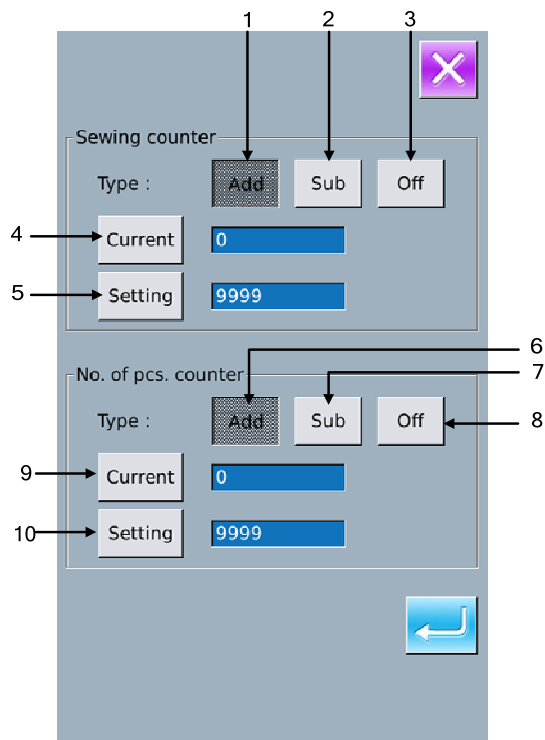

Press  to restore the existing value to the set value.

④ Turn Off Counter

At the selected counter type, press “Off” to turn off the counter.

8.4.1 Functions

| No. | Function |
|-----|--|
| 1 | Sewing Add Counter |
| 2 | Sewing Down Counter |
| 3 | Sewing Counter Off |
| 4 | Set Current Sewing Counter Value |
| 5 | Set the Setting Value of Sewing Counter |
| 6 | No.of Pcs Add Counter |
| 7 | No.of Pcs Down Counter |
| 8 | No.of Pcs Counter Off |
| 9 | Set Current No.of Pcs Counter Value |
| 10 | Set the Setting Value of No.of Pcs Counter |

8.5 Change Sewing Mode

Press  to enter the interface of sewing type selection (as shown in the right figure).

 : Normal Sewing

 : Cyclic Sewing

After confirming the sewing type, press .

to end the operation. Press , then the data input interface of the selected sewing type is displayed.

Press  to quit and the original sewing type remains.

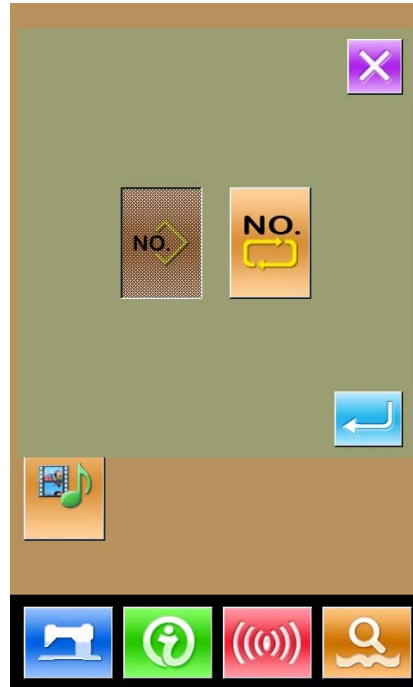

8.6 Have Access to Pattern Edition

Press  to shift between the following two figures and enter the pattern edition mode (Please refer to section 5.1)

 : Sewing Mode

 : Edition Mode

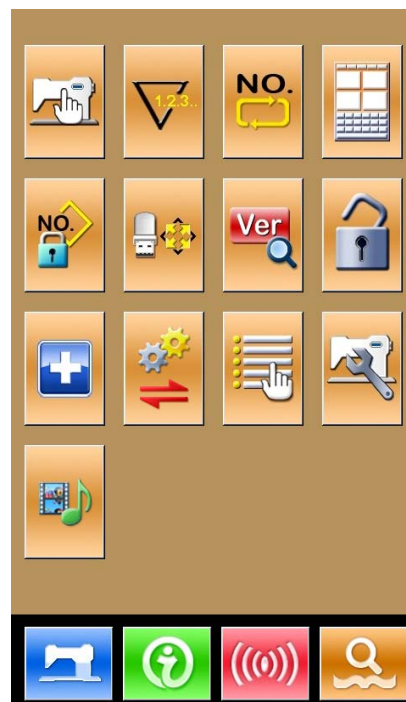

8.7 Set Pattern Lock

In Setting Mode Level 1, press  to enter the interface for setting pattern lock, where the entire pattern number will be displayed. 32 pattern numbers are in each page. For locking a pattern, user only needs to press the pattern number. The selected pattern number will be displayed in dark.

Press  to save the setting. The selected patterns will be locked.



8.8 Initialization

Press  to enter the interface for setting the keyboard lock.

In this interface, user can operate:

- U Disk Initialization
- Memory Initialization
- Customized Initialization
- P and C Pattern Initialization

Press the related function keys and enter the corresponding interface.

Press  to quit.

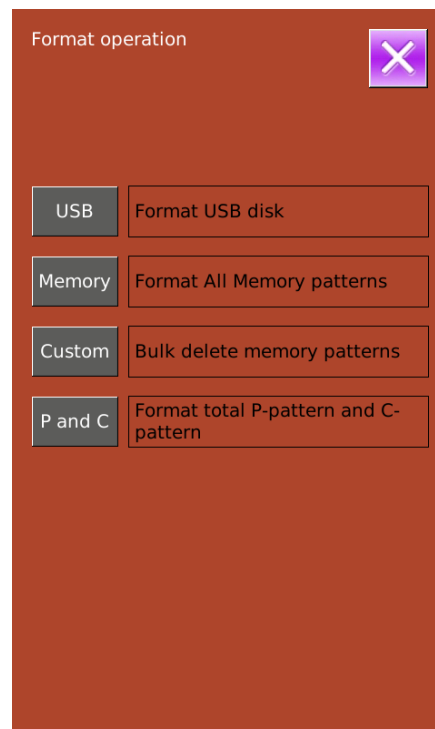

② Press “USB” to Initialize U Disk Files

Press  to initialize all the U disk files

Press  to quit U disk initialization

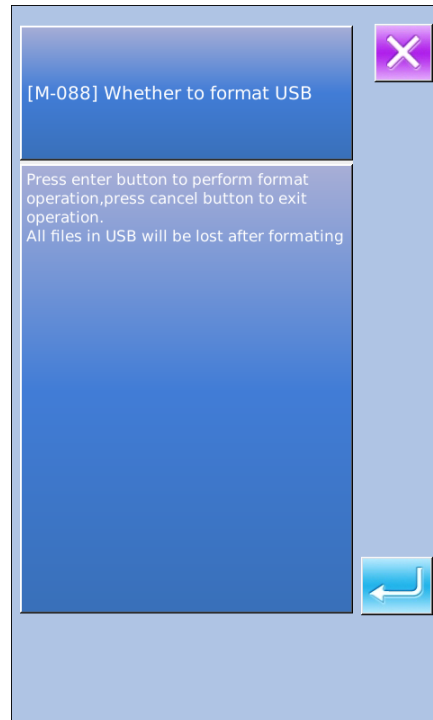

③ Press “Memory” to initialize memory patterns

The following patterns can be initialized:

- Normal Pattern (Basic Patterns & User Patterns)
- Cyclic Sewing Pattern
- Registered P Pattern

Press  to initialize all the files in memory

Press  to quit

※**Caution! This operation will delete all the patterns within the memory!**

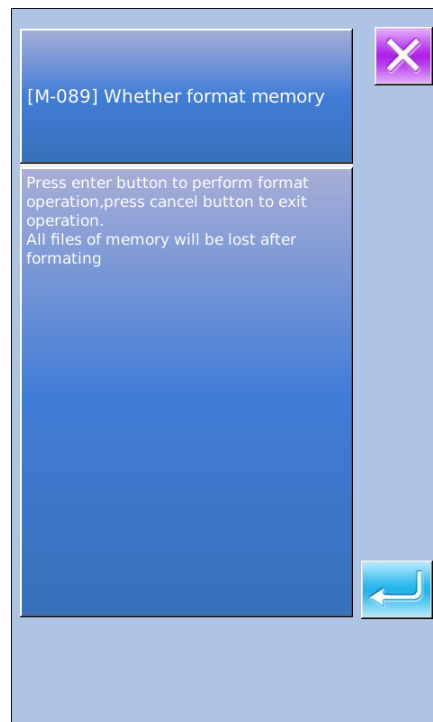



④ Press “Custom” to perform the batch deletion

In this interface, the system will display all the pattern files within the memory. Click the corresponding button to perform the batch deletion.

Operations at this function:

A. Use “Up Arrow”, “Down Arrow” to turn the page

B. Use the following three operations to select patterns

- Press  to select all the patterns
- Press  to select pattern in contrary way
- Input pattern number

C. Press  to delete the patterns in batch

D. Press  to quit Initialization Interface

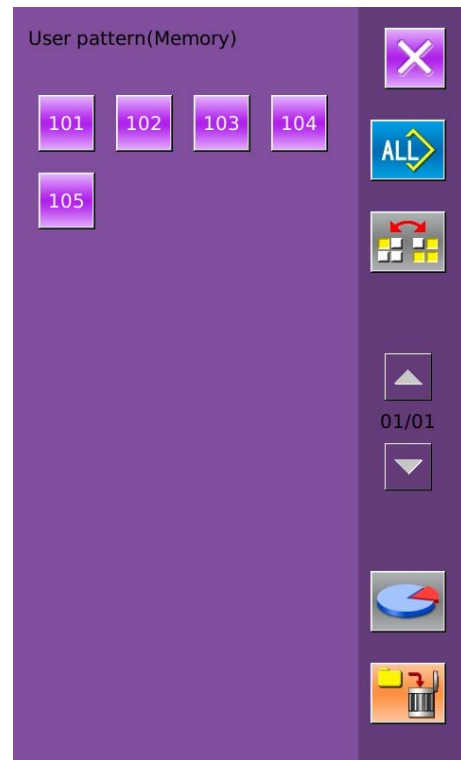

⑤ Under the Interface of Custom

Initialization, press  to display the free room of the memory and the number of patterns in each format.

Press  to return the upper interface.

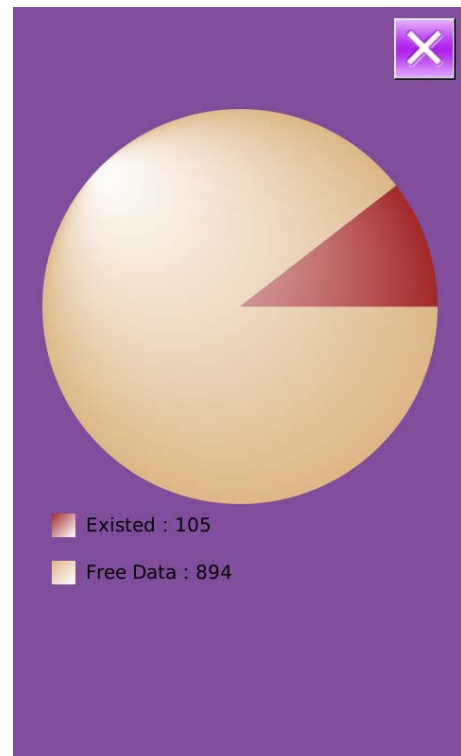

8.9 Software Version Inquiry

At Mode Setting Level 2 Interface, user

can press  to check the software version of system.

 : Save the Current version information to the root directory of U disk.

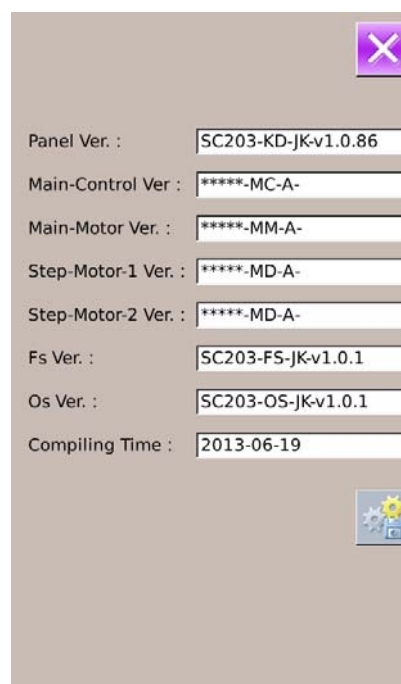

8.10 Test Mode

At Mode Setting Level 2 Interface, user can

press  to have access to the Test Mode Interface (as shown in right picture)

The following is the list of each figure:

| No. | Name |
|-----|----------------------------------|
| A | I01 Touching Panel Correction |
| B | I02 LCD Test |
| C | I03 Input Test |
| D | I04 Speed Test |
| E | I05 Output Test |
| F | I06 Continuous Running |
| G | I07 XY Motor Origin Test |
| H | I09 Presser:/ Origin Sensor Test |

Press  to quit the Test Mode interface

Attention: Only when the level 2 menu is displayed at Maintenance Interface (refer to section 6.2) and level 3 menu is displayed at Mode Interface (refer to section 8), can the items I & J be operated.

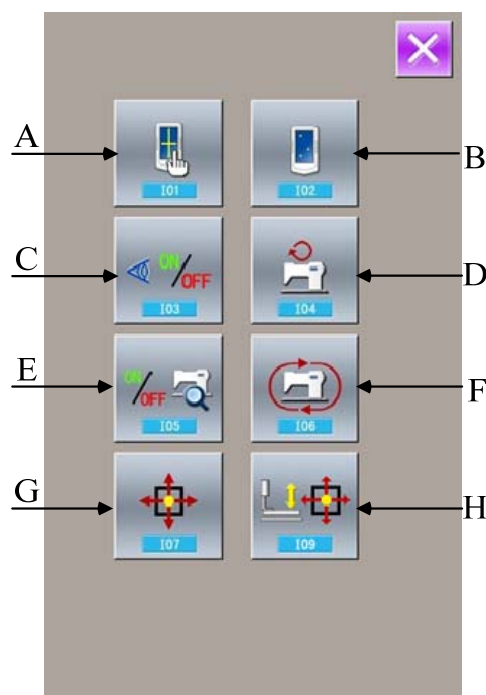



(1) Correction of Touching Panel

A、 In the interface of Mode Inspection,



Press  (I01 Correction of Touch Panel). Then system will hint user 【 Enter Touching Panel Correction

Mode?】 . Press  to enter the interface for Touch Panel Correction (as shown in right figure). Press  to quit the correction status.

B、 Because the corrections for five spots are needed, the user had better click the cross icon on the screen with tools like touching pen. After the correction, the system will tell user that this operation is successful or not.



※During the correction, please do perform the operation according to the positions of crosses. Otherwise, the touching panel will be unable to work normally after the correction.

(2) Inspection of LCD Display

In the interface of Mode Inspection, press



 (I02 Inspection of LCD Display) to enter the interface of LCD Display Inspection (as shown in right figure). Check whether the LCD fades in that status.

Touch the panel to have the screen display in the cycle of “Blue — Black — Red —Green — White”.

Press  to quit the interface of LCD Display Inspection



(3) Input Signal Test Method

In the interface of Test Mode, press  (I03 Input Inspection) to enter the interface of input inspection interface (as shown in right). Users can confirm the input status of each switch and sensor.

ON: Turn On

OFF: Turn Off

01: Start Switch

02: Presser Switch

03: Analog Pedal

04: X Motor Sensor

05: Y Motor Sensor

06: Origin Sensor of Outside-presser Motor

07: Sensor of Head Reversion

08: Sensor of Thread-trimming Motor

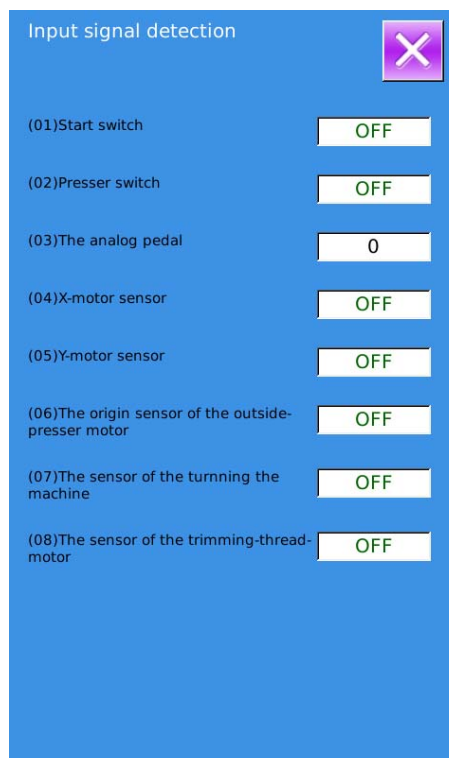

(4) Speed Test

① Interface for Speed Test

In the interface of Mode Inspection, Press



(I04speed test) to enter the interface

for Speed Test (as shown in right figure). The speed of main shaft motor can be tested in that interface.

Press  to quit the interface for speed test.

② Speed Test Setting

Press “+” & “-“ to set the speed of the main

shaft motor. Press , then the motor will run at the set speed. At this moment, the actual tested speed is displayed in the

interface.. Press  to stop the machine

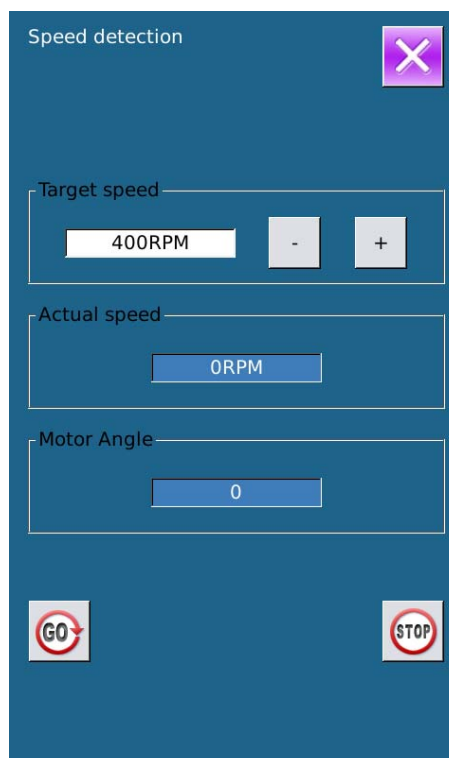

(5) Output Inspection

In the interface of Mode Inspection, Press  (I05 Output Inspection) to enter the interface of Output Inspection (as shown in the right figure). The following output status of the solenoid can be checked under that interface.

- 01: Thread-releasing Solenoid Test
- 02: Needle Thread Solenoid Test

- Press  to quit output inspection interface

※Attention: Sewing machine will perform relating actions.

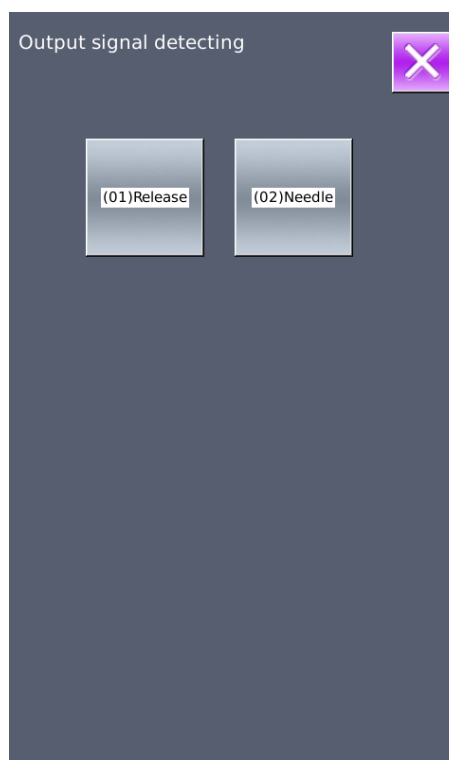

(6) Continuous Running

① Display the interface for continuous running

In the interface of Mode Inspection, Press  (I06 continuous running) to enter the interface of continuous running (as shown in right figure).

- A: Action interval
- B: Origin Detection

Press  to quit that interface.

② Continuous running setting

Click the columns under the interface of Continuous Running to set the Action interval and Origin Detection. Set the value with the number keys.

Press  and step the pedal to start the continuous running. During the running, user can use the pause switch to stop machine or

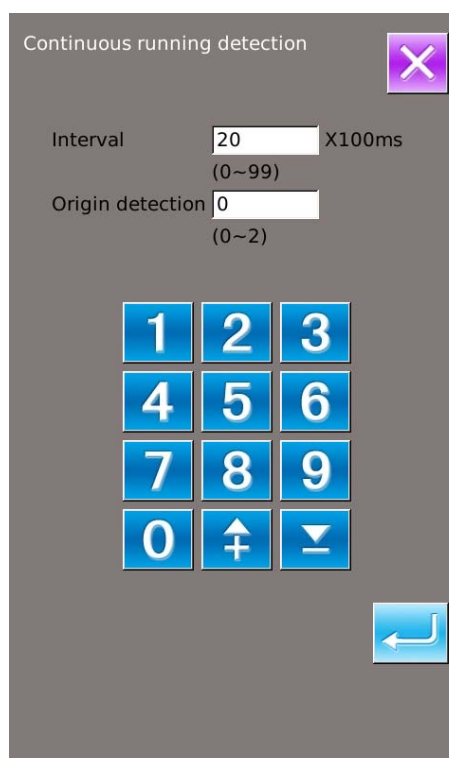

he can stop machine by stepping the pedal or pressing pause switch at action end

(7) XY Motor Origin Sensor Test

At Test Mode Interface, user can press





(I07XY Motor Origin Test) to activate XY Motor/Origin Output Test Interface (as shown in right picture). If user turns on the machine without entering the Ready Status

and pressing  to search the origin, user can directly press the direction keys to move the motor and display the On/Off statuses of Sensors at both XY sides. In this way, user can test the working condition of the XY Motor Driver and their sensors. If user enters the Ready Status after power-on or presses



to search origin, the user will have to

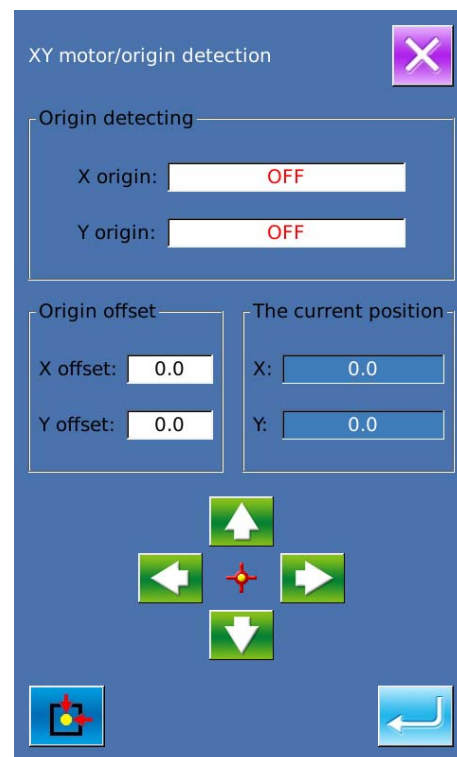

press  to search origin at each entry to the I07 mode in future so that he could use direction keys to move XY motors. This is the manual adjustment of the XY origin. The coordinates displayed at left is the deviation value of the origin, while the coordinates displayed at right is the current position of

presser frame. User can press  to set current position as the reference value of the origin.



(8) Presser Motor / Origin Sensor Detection

According to the status of the presser origin sensor, the position A displays the status (ON/OFF) of presser origin sensor; position B displays the status of trimming sensor.

By using  & , the user can drive the presser motor at each pulse

Additionally, pressing  is to drive presser motor to the position pointed at below, whose figure is displayed in dark.

A: Presser Sensor B: Trimming Sensor

C: Presser down Position

D: Thread-trimming Wait Position

E: Trimming Finish Position

F: Thread-stirring Position

G: Presser Up Position

H: Forward one Step

J: Move to Next Position

I: Backward one Step

Note: Use Switch to search the origin of presser & thread-trimming motor, then this function will be effective.

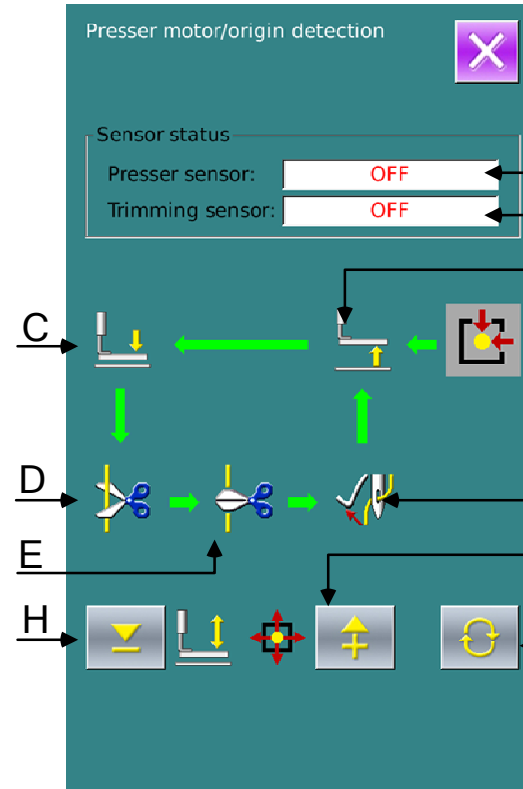

8.11 Keyboard Lock

At Setting Mode Level 2 Interface, user can

press  to activate Keyboard Lock Setting Interface.

① Operation for Keyboard Lock



: Keyboard Unlocked



: Keyboard Locked

Select  and then  to finish the

operation of locking keyboard. Press  to quit the keyboard lock operation.

② Display of Keyboard Lock Status

Close Parameter Setting Mode Interface, and have system return to Sewing Data Input Interface (as shown in right picture.), where

user can see a lock figure  under the pattern number. In the Keyboard Locked status, only the available figures can be displayed.

③ Range of Keyboard Lock

1、Interface of Normal Sewing Data Input:

- 1) Pattern Registration
- 2) Pattern Naming
- 3) Scale Rate Setting
- 4) Max Speed Limitation
- 5) P Pattern Registration
- 6) Pattern Deletion
- 7) Thread
- 8) Pattern Select

2、Normal Sewing Interface:

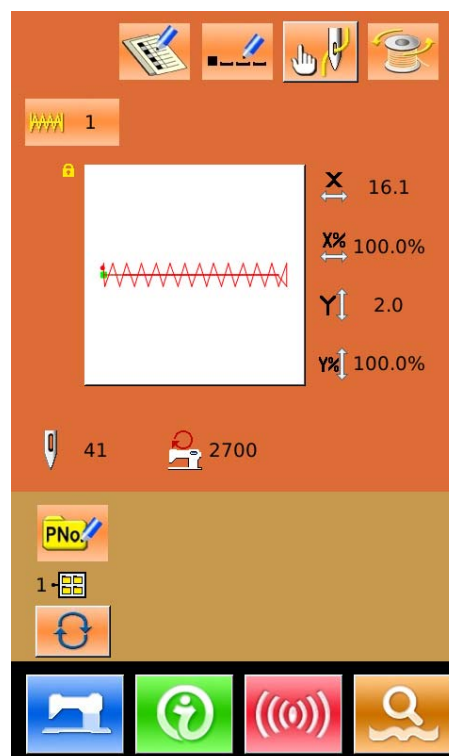
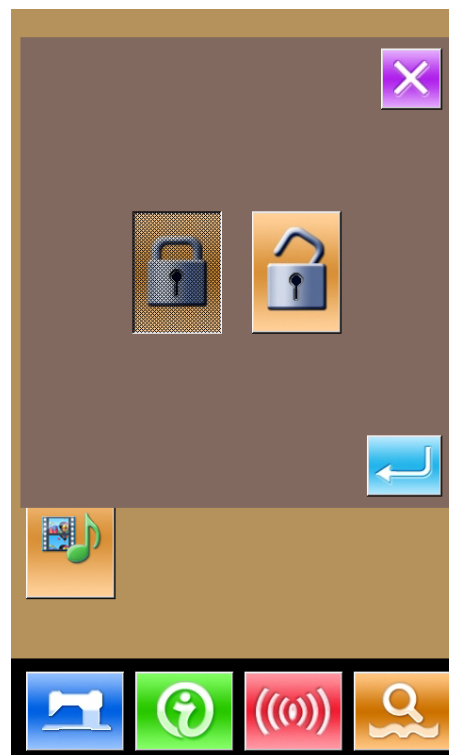

- 1) Frame-moving
- 2) Counter Setting
- 3) Step Sewing
- 4) Return Origion
- 5) Speed Scrollbar
- 3、P Pattern Input Interface:
 - 1) P Pattern Edition
 - 2) P Pattern Copy
 - 3) P Pattern Naming
 - 4) Pattern Deletion
 - 5) Thread
- 4、P Pattern Sewing Interface:
 - 1) Counter Setting
 - 2) Return Origin
 - 3) Step Sewing
 - 4) Speed Scrollbar
- 5、C Pattern Data Input Interface:
 - 1) C Patten Registration
 - 2) C Pattern Copy
 - 3) C Pattern Naming
 - 4) C Pattern Edition
 - 5) Pattern Deletion
 - 6) Speed Scrollbar
 - 7) Return Origin
 - 8) Step Sewing
- 6、C Pattern Sewing Interface:
 - 1) Counter Setting
 - 2) Step Sewing
 - 3) Return Origin
 - 4) C Pattern Switch
- 7、Parameter Setting Mode:
 - 1) Level 1 Parameter
 - 2) Level 2 Parameter
 - 3) Counter edition
 - 4) Test Mode

8.12 Parameter Back-up





In setting mode level 3, press  to enter the interface of parameter back-up & restoration, as shown in right:

Clear: Clear all the customized parameters that are saved.

Save: Save current parameters

Restore: Restore the current parameters

① Click any key among 

~  to set the position for

saving the parameter. And then press 「Save」 to save that parameter.

② Check the content on 「Custom xx (On/Off)」. If 「On」 is displayed in bracket, that means this position has the user parameter,

for an example .

③ Select the button with parameters, press 「Restore」 to reload the corresponding parameter values

④ Press 「Clear」 to delete all the saved parameters

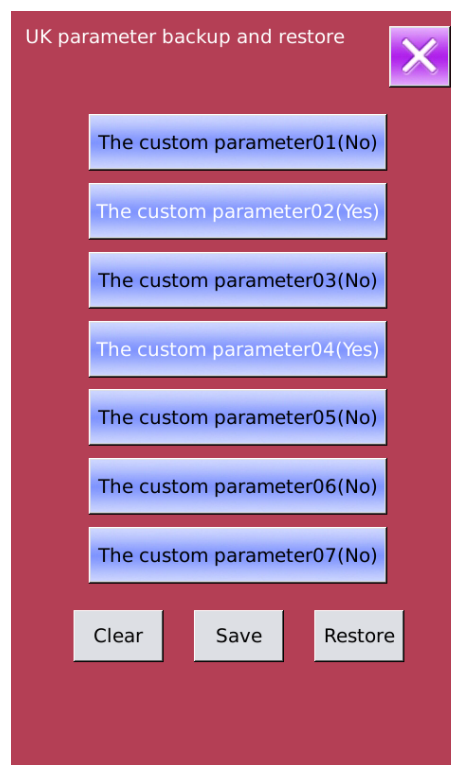

8.13 Button-stitching Function Setting

① Parameter Setting Operation

At Setting mode Level 3 Interface, user can



press  to have access to Level 2 Parameter Setting Interface (as shown in right figure). For the operating methods, please refer to the descriptions in Level 1 or 2 Parameter Setting. Press Key K138 to activate the next interface

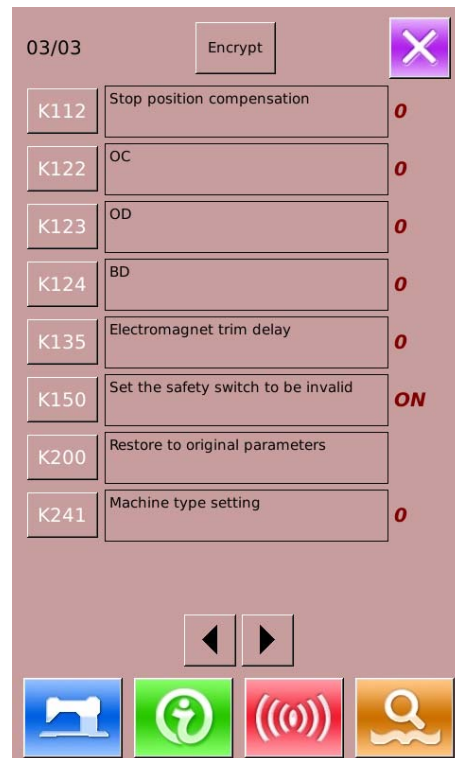

Press  to finish the selection.

Note: When the model is changed, the system will clear the entire saved pattern and reload the pattern for the newly selected model. Therefore, users have to pay attention to backing up patterns before changing the model.

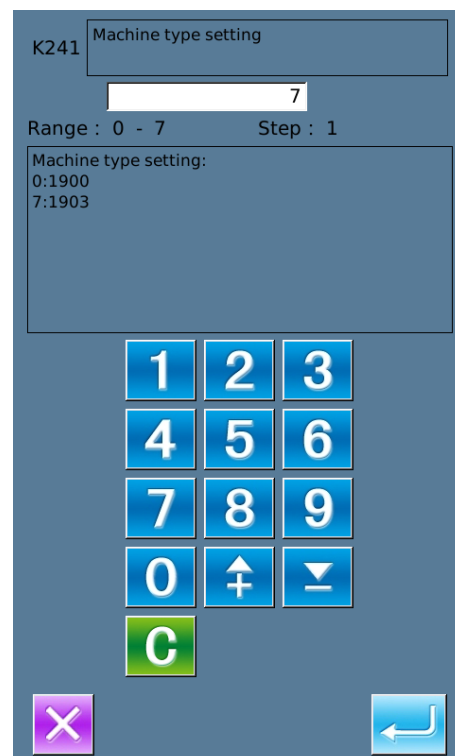

At this moment, the Hint Interface will be displayed, as shown in right picture. Pressing



is to cancel the settings, while pressing



is to confirm clearance of the existed patterns in the old model.

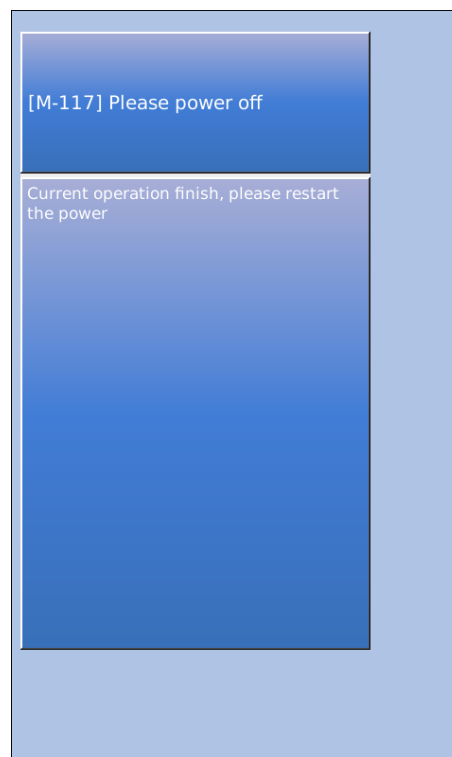
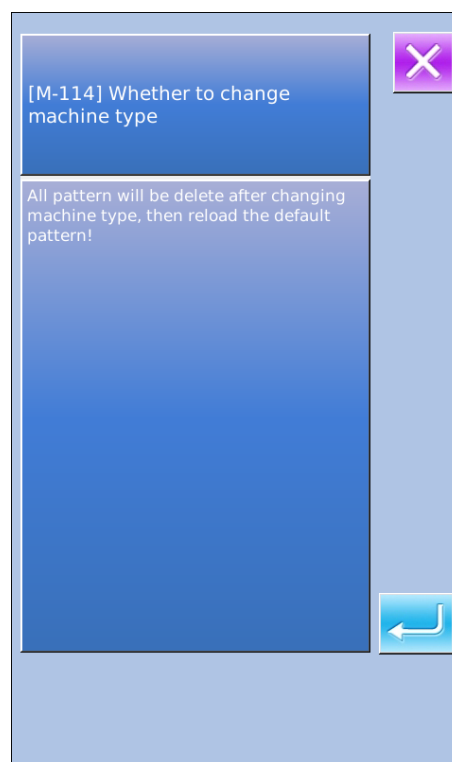

Re-power the machine. The hint interface for reloading patterns of new model will be displayed, as shown in the right picture. The

user only needs to press .

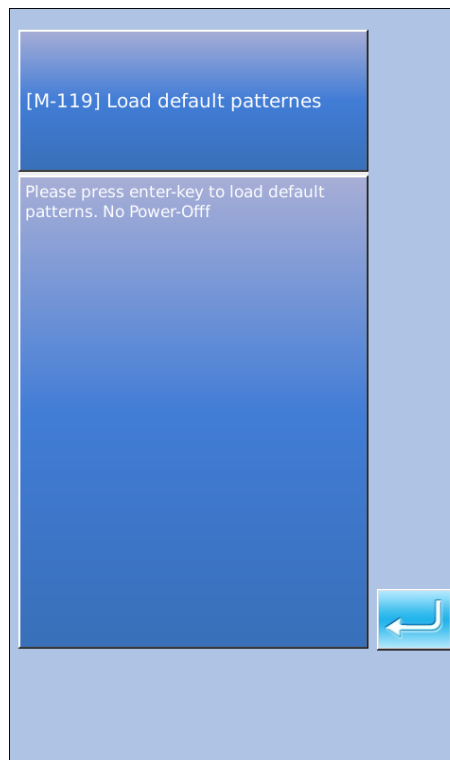

When loading the basic patterns for the new model successfully, the system will activate the Main Interface of Pattern N, as the right picture shows.

Button-sewing function is set successfully!

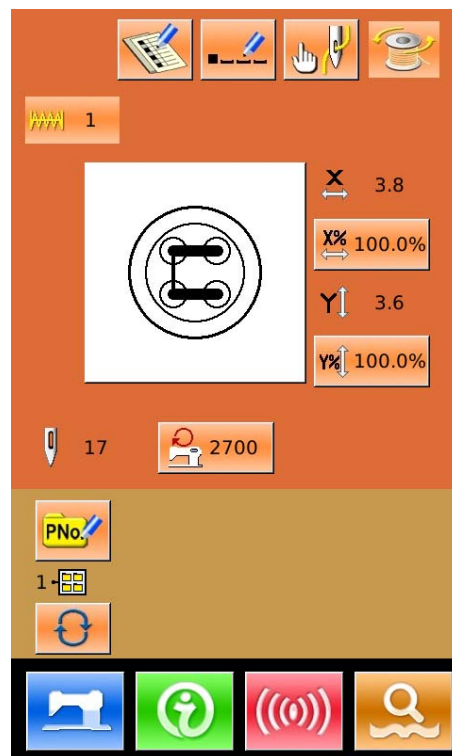

8.14 Pattern Edition Parameter Setting

At Setting Mode Level 3 Interface, user can



press

Setting Pattern Edition Parameters.

The figures of the available functions are displayed in dark, while the figures of the unavailable functions are displayed with highlight.

Edit the parameters according to your





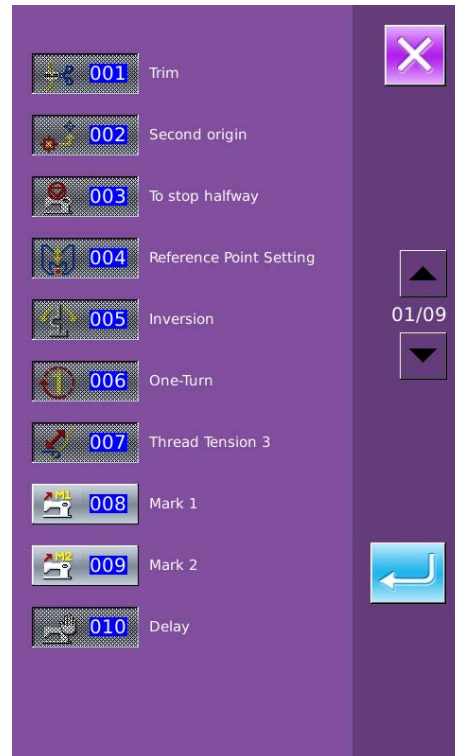

needs, press





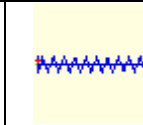
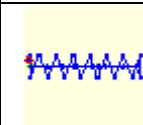

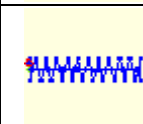
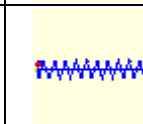
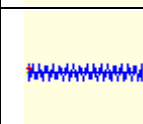
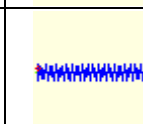
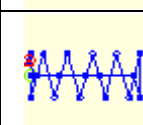
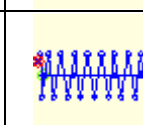
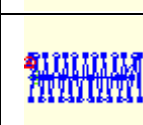
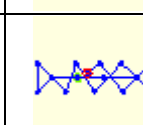
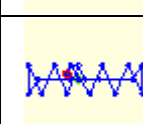
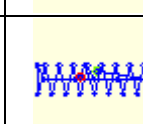

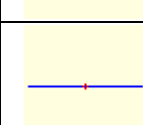
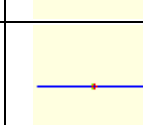
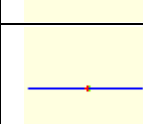
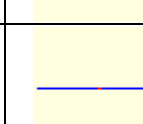
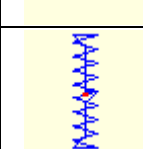
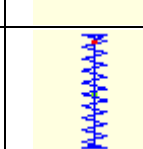
to finish the setting. .

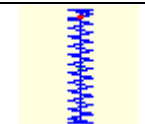
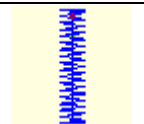
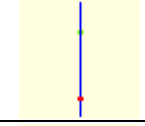
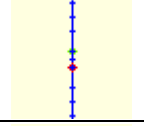
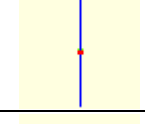
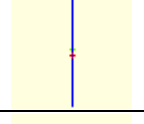

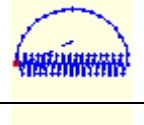
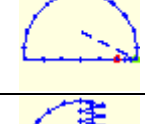
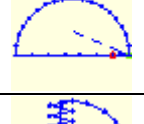
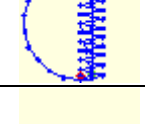
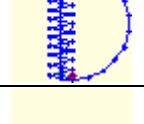
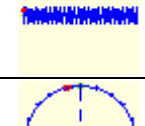
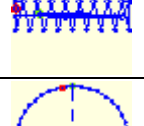
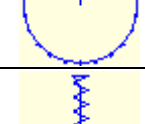
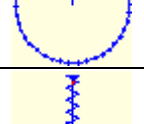

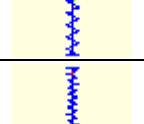
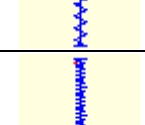
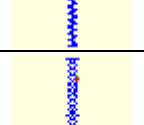
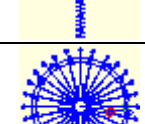
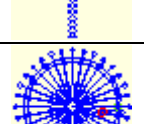
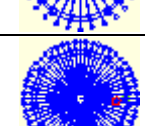
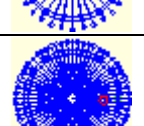
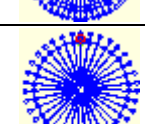
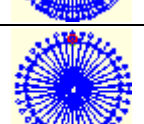
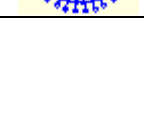





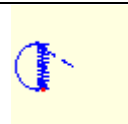

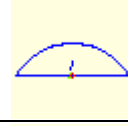
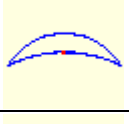
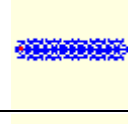
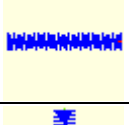

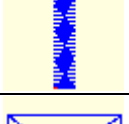
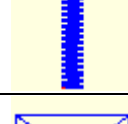
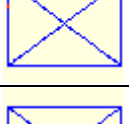
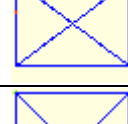
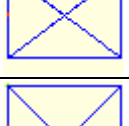
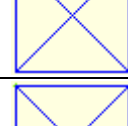
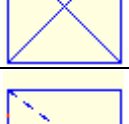
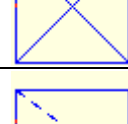
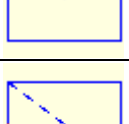
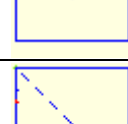
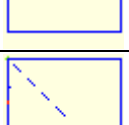
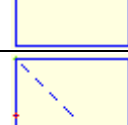
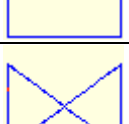
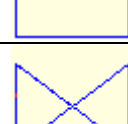
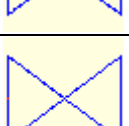
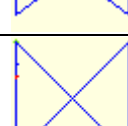
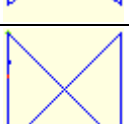
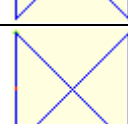
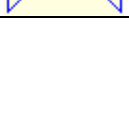
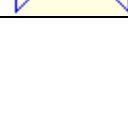

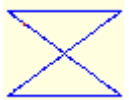
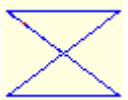

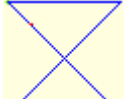

9.2 List of Patterns in Controller

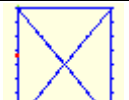
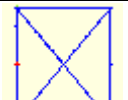
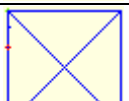
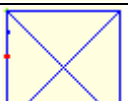
| NO | Patterns | Stitch Number | Length × Width (mm) | NO. | Pattern | Stitch Number | Length × Width (mm) |
|----|---|---------------|---------------------|-----|--|---------------|---------------------|
| 1 |  | 41 | 16.1×2 | 2 |  | 41 | 10.2×2 |
| 3 |  | 41 | 16×2.4 | 4 |  | 41 | 24×3 |
| 5 |  | 27 | 10.1×2 | 6 |  | 27 | 16×2.4 |
| 7 |  | 35 | 10.1×2 | 8 |  | 35 | 16×2.4 |
| 9 |  | 55 | 24×3 | 10 |  | 63 | 24×3 |
| 11 |  | 20 | 6.1×2.4 | 12 |  | 27 | 6.2×2.4 |
| 13 |  | 35 | 6.1×2.4 | 14 |  | 14 | 8×2 |
| 15 |  | 20 | 8×2 | 16 |  | 27 | 8×2 |
| 17 |  | 20 | 10×0 | 18 |  | 27 | 10×0 |
| 19 |  | 27 | 25.2×0 | 20 |  | 35 | 24.8×0 |
| 21 |  | 40 | 25.2×0 | 22 |  | 43 | 35×0 |
| 23 |  | 27 | 4×20 | 24 |  | 35 | 4×20 |







| | | | | | | | |
|----|---|-----|---------|----|--|-----|---------|
| 25 |  | 41 | 4×20 | 26 |  | 55 | 4×20 |
| 27 |  | 17 | 0×20 | 28 |  | 20 | 0×10 |
| 29 |  | 20 | 0×20 | 30 |  | 27 | 0×20 |
| 31 |  | 51 | 10.1×7 | 32 |  | 62 | 12.1×7 |
| 33 |  | 23 | 10.2×6 | 34 |  | 30 | 12×6 |
| 35 |  | 47 | 7×10 | 36 |  | 47 | 7×10 |
| 37 |  | 89 | 24×3 | 38 |  | 27 | 8×2 |
| 39 |  | 25 | 11.8×12 | 40 |  | 45 | 12×12 |
| 41 |  | 28 | 2.4×20 | 42 |  | 38 | 2.4×25 |
| 43 |  | 38 | 2.4×25 | 44 |  | 57 | 2.4×30 |
| 45 |  | 75 | 2.4×30 | 46 |  | 41 | 2.4×30 |
| 47 |  | 89 | 8×8 | 48 |  | 98 | 8×8 |
| 49 |  | 147 | 8×8 | 50 |  | 163 | 8×8 |
| 51 |  | 110 | 7.9×7.9 | 52 |  | 120 | 7.9×7.9 |



























Operation Manual of Doubling & Tacking Machine (Touching Panel)

| | | | | | | | |
|----|---|-----|-----------|----|--|-----|-----------|
| 53 |  | 130 | 7.9×7.9 | 54 |  | 51 | 12.4×10.2 |
| 55 |  | 50 | 12.4×10.2 | 56 |  | 52 | 21×6 |
| 57 |  | 57 | 21×6 | 58 |  | 102 | 19×3 |
| 59 |  | 115 | 40×5 | 60 |  | 115 | 40×5 |
| 61 |  | 93 | 5×30 | 62 |  | 109 | 5×30 |
| 63 |  | 108 | 40×30 | 64 |  | 80 | 40×30 |
| 65 |  | 64 | 40×30 | 66 |  | 96 | 30×30 |
| 67 |  | 76 | 30×30 | 68 |  | 60 | 30×30 |
| 69 |  | 52 | 40×30 | 70 |  | 40 | 40×30 |
| 71 |  | 32 | 40×30 | 72 |  | 44 | 30×30 |
| 73 |  | 36 | 30×30 | 74 |  | 28 | 30×30 |
| 75 |  | 60 | 40×30 | 76 |  | 48 | 40×30 |
| 77 |  | 36 | 40×30 | 78 |  | 56 | 30×30 |
| 79 |  | 44 | 30×30 | 80 |  | 36 | 30×30 |

| | | | | | | | |
|----|---|----|---------|-----|--|----|-------|
| 81 |  | 67 | 40×30 | 82 |  | 51 | 40×30 |
| 83 |  | 39 | 40×30 | 84 |  | 55 | 30×30 |
| 85 |  | 35 | 30×30 | 86 |  | 42 | 30×30 |
| 87 |  | 32 | 30.1×30 | 88 |  | 26 | 30×30 |
| 89 |  | 74 | 20×24 | 90 |  | 54 | 20×24 |
| 91 |  | 65 | 20×20 | 92 |  | 49 | 20×20 |
| 93 |  | 39 | 20×20 | 94 |  | 63 | 25×20 |
| 95 |  | 51 | 25×20 | 96 |  | 45 | 25×20 |
| 97 |  | 42 | 25×20 | 98 |  | 33 | 25×20 |
| 99 |  | 27 | 25×20 | 100 |  | 88 | 30×25 |

9.3 List of Patterns for Button-sewing in Controller











| No. | Pattern | Thread Number | Standard Sewing Length X(mm) | Standard Sewing Length Y(mm) | No. | Pattern | Thread Number | Standard Sewing Length X(mm) | Standard Sewing Length Y(mm) |
|------|---|---------------|------------------------------|------------------------------|-------|--|---------------|------------------------------|------------------------------|
| 1-34 |  | 6-6 | 3.4 | 3.4 | 18-44 |  | 6 | 3.4 | 0 |
| 2-35 |  | 8-8 | | | 19-45 |  | 8 | | |
| 3 |  | 10-10 | | | 20 |  | 10 | | |

| No. | Pattern | Thread Number | Standard Sewing Length X(mm) | Standard Sewing Length Y(mm) | No. | Pattern | Thread Number | Standard Sewing Length X(mm) | Standard Sewing Length Y(mm) |
|-------|---|---------------|------------------------------|------------------------------|-------|--|---------------|------------------------------|------------------------------|
| 4 |  | 12-12 | | | 21 |  | 12 | | |
| 5-36 |  | 6-6 | | | 22 |  | 16 | | |
| 6-37 |  | 8-8 | | | 23-46 |  | 6 | | |
| 7 |  | 10-10 | | | 24 |  | 10 | | |
| 8 |  | 12-12 | | | 25 |  | 12 | | |
| 9-38 |  | 6-6 | | | 26-47 |  | 6-6 | | |
| 10-39 |  | 8-8 | | | 27 |  | 10-10 | | |
| 11 |  | 10-10 | | | 28-48 |  | 6-6 | | |
| 12-40 |  | 6-6 | | | 29 |  | 10-10 | | |
| 13-41 |  | 8-8 | | | 30-49 |  | 5-5-5 | 3.0 | 2.5 |
| 14 |  | 10-10 | | | 31 |  | 8-8-8 | | |
| 15-42 |  | 6-6 | | | 32-50 |  | 5-5-5 | | |
| 16-43 |  | 8-8 | | | 33 |  | 8-8-8 | | |
| 17 |  | 10-10 | | | | | | | |

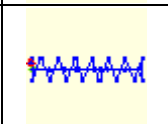
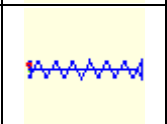
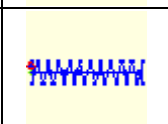
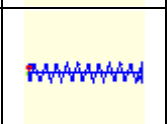
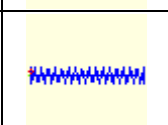
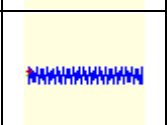

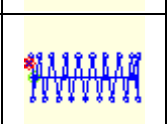

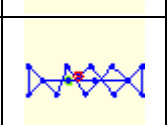
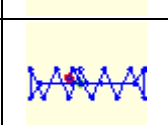
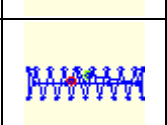

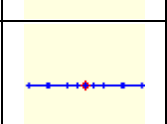
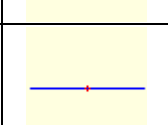
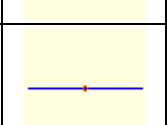
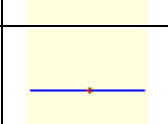
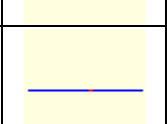
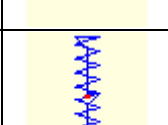
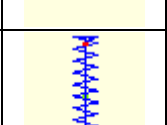
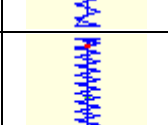
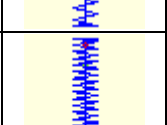
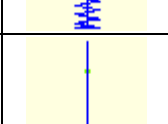
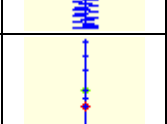



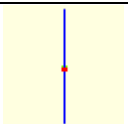
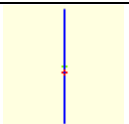

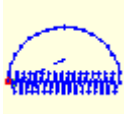
9.4 List of Patterns for Doubling in Controller



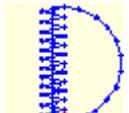
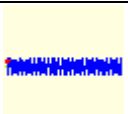

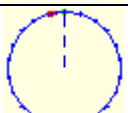
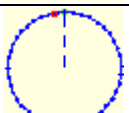
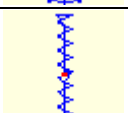
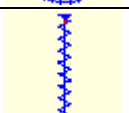
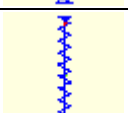
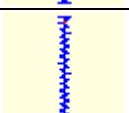
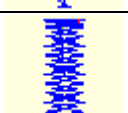
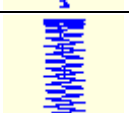
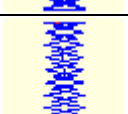



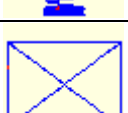
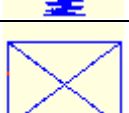
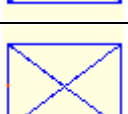
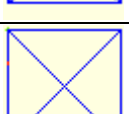
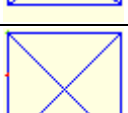
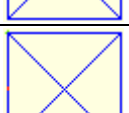



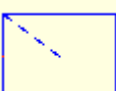

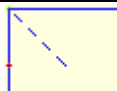



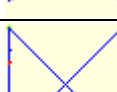



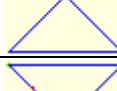
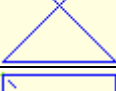
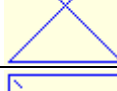

| NO. | Patterns | Stitch Number | Length × Width (mm) | NO. | Patterns | Stitch Number | Length × Width (mm) |
|-----|----------|---------------|---------------------|-----|----------|---------------|---------------------|
| | | | | | | | |

Operation Manual of Doubling & Tacking Machine (Touching Panel)

| | | | | | | | |
|----|---|----|---------|----|--|----|---------|
| 1 |  | 41 | 16.1×2 | 2 |  | 41 | 10.2×2 |
| 3 |  | 41 | 16×2.4 | 4 |  | 41 | 24×3 |
| 5 |  | 27 | 10.1×2 | 6 |  | 27 | 16×2.4 |
| 7 |  | 35 | 10.1×2 | 8 |  | 35 | 16×2.4 |
| 9 |  | 55 | 24×3 | 10 |  | 63 | 24×3 |
| 11 |  | 20 | 6.1×2.4 | 12 |  | 27 | 6.2×2.4 |
| 13 |  | 35 | 6.1×2.4 | 14 |  | 14 | 8×2 |
| 15 |  | 20 | 8×2 | 16 |  | 27 | 8×2 |
| 17 |  | 20 | 10×0 | 18 |  | 27 | 10×0 |
| 19 |  | 27 | 25.2×0 | 20 |  | 35 | 24.8×0 |
| 21 |  | 40 | 25.2×0 | 22 |  | 43 | 35×0 |
| 23 |  | 27 | 4×20 | 24 |  | 35 | 4×20 |
| 25 |  | 41 | 4×20 | 26 |  | 55 | 4×20 |
| 27 |  | 17 | 0×20 | 28 |  | 20 | 0×10 |

Operation Manual of Doubling & Tacking Machine (Touching Panel)

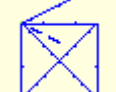

| | | | | | | | |
|----|---|-----|---------|----|--|-----|---------|
| 29 |  | 20 | 0×20 | 30 |  | 27 | 0×20 |
| 31 |  | 51 | 10.1×7 | 32 |  | 62 | 12.1×7 |
| 33 |  | 23 | 10.2×6 | 34 |  | 30 | 12×6 |
| 35 |  | 47 | 7×10 | 36 |  | 47 | 7×10 |
| 37 |  | 89 | 24×3 | 38 |  | 27 | 8×2 |
| 39 |  | 25 | 11.8×12 | 40 |  | 45 | 12×12 |
| 41 |  | 28 | 2.4×20 | 42 |  | 38 | 2.4×25 |
| 43 |  | 38 | 2.4×25 | 44 |  | 57 | 2.4×30 |
| 45 |  | 141 | 10×30 | 46 |  | 122 | 10×30 |
| 47 |  | 97 | 10×30 | 48 |  | 109 | 10.1×30 |
| 49 |  | 122 | 10.1×30 | 50 |  | 265 | 10×30 |
| 51 |  | 108 | 40×30 | 52 |  | 80 | 40×30 |
| 53 |  | 64 | 40×30 | 54 |  | 96 | 30×30 |
| 55 |  | 76 | 30×30 | 56 |  | 60 | 30×30 |

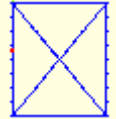
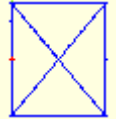
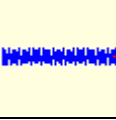
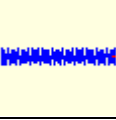
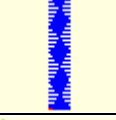
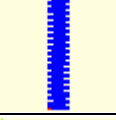
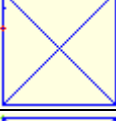
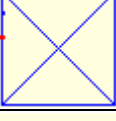
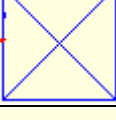
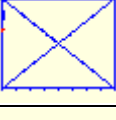
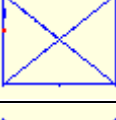
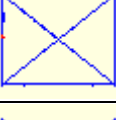
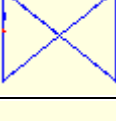
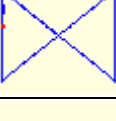
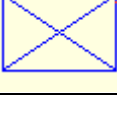
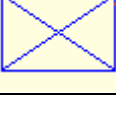



| | | | | | | | |
|----|---|----|-------|----|--|-----|---------|
| 57 |  | 52 | 40×30 | 58 |  | 40 | 40×30 |
| 59 |  | 32 | 40×30 | 60 |  | 44 | 30×30 |
| 61 |  | 36 | 30×30 | 62 |  | 28 | 30×30 |
| 63 |  | 60 | 40×30 | 64 |  | 48 | 40×30 |
| 65 |  | 36 | 40×30 | 66 |  | 56 | 30×30 |
| 67 |  | 44 | 30×30 | 68 |  | 36 | 30×30 |
| 69 |  | 67 | 40×30 | 70 |  | 51 | 40×30 |
| 71 |  | 39 | 40×30 | 72 |  | 55 | 30×30 |
| 73 |  | 43 | 30×30 | 74 |  | 35 | 30×30 |
| 75 |  | 42 | 30×30 | 76 |  | 32 | 30.1×30 |
| 77 |  | 26 | 30×30 | 78 |  | 103 | 30×25 |
| 79 |  | 82 | 30×25 | 80 |  | 64 | 30×25 |
| 81 |  | 80 | 20×30 | 82 |  | 60 | 20×30 |
| 83 |  | 80 | 30×20 | 84 |  | 60 | 30×20 |

| | | | | | | | |
|----|---|-----|-------|-----|--|-----|-------|
| 85 |  | 74 | 20×24 | 86 |  | 54 | 20×24 |
| 87 |  | 115 | 40×5 | 88 |  | 115 | 40×5 |
| 89 |  | 93 | 5×30 | 90 |  | 109 | 5×30 |
| 91 |  | 65 | 20×20 | 92 |  | 49 | 20×20 |
| 93 |  | 39 | 20×20 | 94 |  | 63 | 25×20 |
| 95 |  | 51 | 25×20 | 96 |  | 45 | 25×20 |
| 97 |  | 42 | 25×20 | 98 |  | 33 | 25×20 |
| 99 |  | 111 | 60×40 | 100 |  | 91 | 60×40 |

9.5 List of Warning

| Code | Name | Release Method |
|-------|--------------------------------------|---|
| E-001 | Pedal is not at the middle position. | Check whether pedal is stepped at entering the Ready Sewing Interface |
| E-002 | Machine is in emergency stop | Press  to enter the Status of frame-moving at stop or press Reset Switch to trim thread and restart or return to origin. |
| E-003 | Tilt of Machine Head Error | Press Enter. Machine can not run at status of head tilt. Please return to the normal position. The technician can use the short connect block to short the 2P blue plug on SC047A board. |
| E-004 | Main voltage is too low (300V) | Turn off Machine |
| E-005 | Main voltage is too high (300V) | Self-recovery |
| E-007 | IPM over-voltage or over current | Turn off Machine |
| E-008 | Voltage of assistant device (24V) is | Turn off Machine |

| Code | Name | Release Method |
|-------|---|---|
| | too high | |
| E-009 | Voltage of assistant device (24V) is too low | Turn off power. Please re-power the machine after a while. Meanwhile, user also has to ensure no short circuit at solenoids connecting X11 port. |
| E-010 | Valve (fan) problem | Turn off Machine |
| E-013 | Encoder error or unconnected | Turn off power and check the connection at X5 port. |
| E-014 | Motor running abnormal | Turn off Machine. Check the signal from motor encoder |
| E-015 | Exceeds sewing area | Press Reset switch, and confirm the figure and X/Y scale rate. Activating Condition: Software Pattern Error |
| E-016 | Needle bar upper position abnormal | Press  . The wrong stop position of main motor may be caused by the main shaft driver or the manual rotation. Turn the wheel to return the needle bar to the upper position. |
| E-017 | Thread breakage detection error | Press  |
| E-018 | Knife position abnormal | Turn off power. Check the connecting condition of CZ024 on head signal board. If that is ok, please check trimming coupler. |
| E-019 | Emergency switch is not at the right position | Self-recovery |
| E-020 | Stepping software version error | Turn off machine. Make sure the used stepping board and the board program are correct |
| E-021 | Machine is in emergency stop (Free) | Press Reset |
| E-022 | Machine is in emergency stop (Ready) | Press Reset |
| E-023 | Thread-catching position error | Turn off Machine |
| E-024 | Wrong connection between operation panel and sewing machine | Turn off Machine |
| E-025 | X origin detection abnormal | Turn off power. Check the connecting condition of X9 port (on control box) and CZ021 port (on head signal board). |
| E-026 | Y origin detection abnormal | Turn off power. Check the connecting condition of X9 port (on control box) and CZ022 port (on head signal board). |
| E-027 | Presser origin detection abnormal | Turn off power. Check the connecting condition of X9 port (on control box) and CZ025 port (on head signal board). |
| E-028 | Thread-catching origin detection abnormal | Turn off Machine |
| E-029 | Intermediate presser origin detection | Turn off Machine |

| Code | Name | Release Method |
|-------|--|---|
| | abnormal | |
| E-030 | Stepping driver communication abnormal | Turn off power. Re-power the machine after a while. Check the condition of communication cable, mother board and driving board. |
| E-031 | Stepping motor over-current | Turn off power. Re-power the machine after a while. |
| E-032 | Stepping driver power supply abnormal | Turn off Machine |
| E-034 | Abnormal current | Turn off machine. Check the condition of the main motor driving circuit, encoder response signal and mechanical load in order |
| E-035 | IPM frequent over-current 1 | Turn off machine. Check the condition of the main motor driving circuit, encoder response signal and mechanical load in order |
| E-036 | IPM frequent over-current 2 | Turn off machine. Check the condition of the main motor driving circuit, encoder response signal and mechanical load in order |
| E-037 | Motor blockage 1 | Press  |
| E-038 | Motor blockage 2 | After the action order is sent to main motor, main motor has to response. Check the 6-line PWM wave of main motor driving circuit and response signal of encoder. At last, make sure the mechanism has no blockage. |
| E-039 | Motor over speed | Turn off power and turn it on after a while |
| E-040 | Stop over-current | Turn off Machine |
| E-041 | Motor overload | Turn off Machine |
| E-042 | Bus voltage abnormal | Press  |
| E-043 | Thread-trimming motor origin abnormal | Press  |
| E-044 | Head board EEPROM loading error | Press  |
| E-045 | Component abnormal | Turn off Machine |
| E-046 | CRC checking error | Turn off Machine |
| E-047 | Data checking error | Turn off Machine |
| E-048 | X checking error | Communication error between main control board and stepping board |
| E-049 | Y checking error | Communication error between main control board and stepping board |
| E-050 | MD1 stepping motor over-current | Turn off machine and check the stepping driving board and stepping motor |
| E-051 | MD1 X direction not finish | Turn off machine. The main controller sends the new |

| Code | Name | Release Method |
|-------|---------------------------------|---|
| | | action order before the stepping device finish the current order. |
| E-052 | MD1 Y direction not finish | Turn off machine. The main controller sends the new action order before the stepping device finish the current order. |
| E-053 | MD2 stepping motor over-current | Turn off machine and check the stepping driving board and stepping motor |
| E-054 | MD2 X direction not finish | Turn off machine. The main controller sends the new action order before the stepping device finish the current order. |
| E-055 | MD2 Y direction not finish | Turn off machine. The main controller sends the new action order before the stepping device finish the current order. |
| E-254 | Undefined error | Press  |

9.6 Hint List

| No. | Name | Content |
|-------|--|--|
| M-001 | Can not find pattern data | Please reload or input from design software |
| M-002 | Set value too large | Please input value within range |
| M-003 | Set value too small | Please input value within range |
| M-004 | Parameter save error | Press Enter to recover default setting |
| M-005 | Communication error | Communication error between operation panel and control box |
| M-006 | Fail to load letter sewing file | |
| M-007 | Operation head not match to control box | Please check the model and the software version |
| M-008 | Over Max stitch pitch | |
| M-009 | Wrong password | Input again |
| M-010 | Clock error | The hardware clock is down, please contact manufacturer for repair |
| M-011 | Letter sewing pattern saved successfully | Enter the pattern selection interface and generate new letter sewing pattern |
| M-012 | SRAM initialization | Clear all the data within SRAM, please turn off machine and restore the DIP switch |
| M-013 | Turning off | |
| M-014 | USB is pulled out | USB is pulled out |
| M-015 | Can not find pattern in U disk | |

| | | |
|-------|---|---|
| M-016 | At least input one letter | Periodical password has been set, can not change system time |
| M-017 | No warning record | |
| M-018 | Wrong user ID | Input again |
| M-019 | Fail to confirm password | Input password again |
| M-020 | Can not change system time | Periodical password has been set, can not change system time |
| M-021 | Password file input error | |
| M-022 | Password file load error | |
| M-023 | Password save successful | |
| M-024 | Clear all password failed | Can not delete password file |
| M-025 | Fail to clear password | After clearance of password, the input of file has problem |
| M-026 | Password file is deleted without authorization | Password file is deleted without authorization, please turn off machine |
| M-027 | User ID file damaged | |
| M-028 | Can not input blank | Input password again |
| M-029 | Current password not match | Input current password again |
| M-030 | New password not match | Input new password again |
| M-031 | Enter touching panel correction mode | Are You Sure? Yes: enter No: X |
| M-032 | Correction successful | Correction is successful, please restart machine |
| M-033 | Correction failed | Please perform correction again |
| M-034 | Clear warning record | Are You Sure? Yes: enter No: X |
| M-035 | Periodical password is same to super password error | Input password again |
| M-036 | Pattern data error | Current pattern data error, it will be replaced by default patterns |
| M-037 | Pattern information file open failed | Restore to default pattern configuration |
| M-038 | Memory full | Please delete the unused patterns |
| M-039 | Cover the pattern | Are You Sure? Yes: enter No: X |
| M-040 | P pattern open error | Pattern file has mistake, it will be deleted |
| M-041 | C pattern open error | Pattern file has mistake, it will be deleted |
| M-042 | Pattern is existed | Can not replace the pattern |
| M-043 | Delete pattern data | Press Enter to delete; Press ESC to quit |
| M-044 | Delete the selected pattern | Are You Sure? Yes: enter No: X |
| M-045 | Pattern is used, can not delete | Please release the quotation at P or C pattern |
| M-046 | Save at lease one pattern | Can not delete last pattern |
| M-047 | Load default patterns | No pattern in memory, please load default patterns |
| M-048 | No pattern in memory | Press Enter to load default patterns |

| | | |
|-------|---|--|
| M-049 | Pattern number not exist | Please input again |
| M-050 | P pattern not exist | Please create P pattern |
| M-051 | Save software version successful | Software version is saved to the root directoty of U disk |
| M-052 | Replace needle | Needle replacement set value is reached, please replace needle |
| M-053 | Replace oil | Oil replacement set value is reached, please replace oil |
| M-054 | Clean machine | Cleaning machine set value is reached, please clean machine |
| M-055 | Clear needle replacement set value | Are You Sure? Yes: enter No: X |
| M-056 | Clear oil replacement set value | Are You Sure? Yes: enter No: X |
| M-057 | Clear cleaning time value | Are You Sure? Yes: enter No: X |
| M-058 | Clear production control value | Are You Sure? Yes: enter No: X |
| M-059 | Clear calculated running time | Are You Sure? Yes: enter No: X |
| M-060 | Clear calculated sewing number? | Are You Sure? Yes: enter No: X |
| M-061 | Clear calculated power-on time? | Are You Sure? Yes: enter No: X |
| M-062 | Clear calculated sewing stitch number? | Are You Sure? Yes: enter No: X |
| M-063 | Clear calculated over-current times? | Are You Sure? Yes: enter No: X |
| M-064 | Clear calculated stop times? | Are You Sure? Yes: enter No: X |
| M-065 | Edit new pattern? | Are You Sure? Yes: enter No: X |
| M-066 | Return to sewing mode? | Are You Sure? Yes: enter No: X |
| M-067 | Restore all the settings | Are You Sure? Yes: enter No: X |
| M-068 | Restore the selected items | Are You Sure? Yes: enter No: X |
| M-069 | Not select an item | Please select one or several parameters |
| M-070 | Sewing counter reaches set value | Please pres Enter to cleat it |
| M-071 | No.of pcs counter reaches set value | Please pres Enter to cleat it |
| M-072 | Successful | Current operation is successful |
| M-073 | Failed | Current operation is failed |
| M-074 | Copy failed | Check the room of memory |
| M-075 | Copy failed | Check whether the U disk is pulled out |
| M-076 | File I/O error | File I/O error |
| M-077 | Verification failed at updating main software | |
| M-078 | Can not delete pattern data | The selected sewing data is in use |
| M-079 | Perform parameter transfer | Are You Sure? Yes: enter No: X |
| M-080 | Can not open changed pattern | Please confirm pattern file |
| M-081 | Changed pattern format error | Please confirm pattern file |
| M-082 | Changed pattern data is too long | Please confirm pattern file |
| M-083 | Update successful | Update successful, please restart machine |

| | | |
|-------|--|--|
| M-084 | Fail to open file | Fail to open file |
| M-085 | Parameter restoration successful | Parameter restoration successful, please restart machine |
| M-086 | Not select update item | Please select at least one item for update |
| M-087 | Selected item for update is not existed | If the item has no update file, the system will cancel the selection. If user wants to update the rest, please confirm again |
| M-088 | Initialize U disk | Press Enter to perform operation; Press ESC to quit. The initialization will delete all the files in U disk |
| M-089 | Initialize memory | Press Enter to perform operation; Press ESC to quit. The initialization will delete all the files in memory |
| M-090 | Low memory | |
| M-091 | Fail to select the function | |
| M-092 | Shape point repeated error | |
| M-093 | Can not return | |
| M-094 | Can not find next stitch sewing data | |
| M-095 | Can not find previous stitch sewing data | |
| M-096 | Pattern data is too big | |
| M-097 | Calculation error | |
| M-098 | Pattern-designing error | |
| M-099 | Cannot find the pattern | |
| M-100 | Over moving range | |
| M-101 | Over sewing range | Make sure pattern within sewing range |
| M-102 | Stitch number over range | Reduce stitch number |
| M-103 | Pattern file error | |
| M-104 | Confirm to change point | |
| M-105 | Confirm to insert auto trimming code | |
| M-106 | Delete new pattern? | Press Enter to confirm; Press ESC to quit |
| M-107 | Delete elements? | Press Enter to confirm; Press ESC to quit |
| M-108 | Confirm to perform? | Press Enter to confirm; Press ESC to quit |
| M-109 | Delete mechanical control order? | Press Enter to confirm; Press ESC to quit |
| M-110 | Delete needle entry point | Press Enter to confirm; Press ESC to quit |
| M-111 | Are you sure to move presser? | Press Enter to confirm; Press ESC to quit |
| M-112 | Delete shape point | Press Enter to confirm; Press ESC to quit |
| M-113 | Warning: initialization will delete entire data in memory! | Press Enter to confirm; Press ESC to quit |
| M-114 | Change model? | Press Enter to confirm; Press ESC to quit |
| M-115 | Pattern is locked | Please unlock first |

| | | |
|-------|------------------------------------|---|
| M-116 | Can not modify basic pattern | |
| M-117 | Turn off machine. | Current operation is finished, please restart machine |
| M-118 | Can not modify counter | At modification, please turn off setting |
| M-119 | Load basic pattern | Press ENTER to load basic pattern, don't turn off machine ! |
| M-120 | Restore to default setting? | Press Enter to confirm; Press ESC to quit |
| M-121 | Clear entire custom parameters? | Are You Sure? Yes: enter No: X |
| M-122 | Head board parameter error | Press ENTER to restore to default values |
| M-123 | Pattern calculation error | |
| M-124 | Delete all the P and C patterns | Press Enter to confirm; Press ESC to quit |
| M-125 | Restore head board parameters? | Are You Sure? Yes: enter No: X |
| M-126 | Over setting range | |
| M-127 | Can not find customized pattern | This operation is only available for customized pattern. The basic pattern can not be outputted! |
| M-128 | Outer presser is at upper position | Please lower the presser to perform the operation! |
| M-129 | Can not perform right operation | |
| M-130 | Can not find USB | Please insert U disk containing mp3 file |
| M-131 | No video files in vid.avi | Please put vid.avi file into pdat directory in U disk and then enter the update interface to update video files |

----- 全文完 -----